

**Side-channel Attack Standard Evaluation Board
SASEBO-GIII Specification**

- Version 1.1 -

April 26, 2013

Research Institute for Secure Systems,
National Institute of Advanced Industrial Science and Technology

Table of Contents

1. Overview	3
2. Operational Instructions.....	5
2.1. Power Circuit.....	7
2.2. Voltage Calibration	7
2.3. Power-On Sequences	8
2.4. Configuration.....	9
2.5. Clock System	10
2.6. Measurement Points	10
2.7. Connectors	11
2.8. Switches	14
3. I/O Assignments	15
3.1. Kintex-7.....	15
3.2. Spartan-6	22
3.3. FPGA Interconnects	27
4. Parts List, Schematic, and Board Layout	30

1. Overview

The SASEBO-GIII is a successor of SASEBO-GII board, and is for further side-channel attack experimentation. The board has Xilinx 28-nm Kintex-7 FPGA device, which enables advanced measurement with on-the-edge technology. The basic features of SASEBO-GIII are as follows:

- 200 mm x 150 mm x 1.6mm, FR-4, eight layers.
- Two Xilinx FPGAs
 - Cryptographic FPGA: Kintex-7 XC7K160T-1FBGC
 - Control FPGA: Spartan-6 XC6LX45-2FGG484C
- 1 Gigabit DDR3 SDRAM.
- External power source supplies the on-board power regulators and the FPGAs with 5.0 V.
- Shunt resistor is provided to insert on the core VDD line of the cryptographic FPGA for measuring power traces.
- The host PC controls and communicates with the board via the USB port.

Table 1 : Specification

FPGA #1	FPGA	Xilinx Kintex-7 XC7K160T-1FBG676C
	Configuration ROM	64Mbit BPI Flash Memory PC28F640P30TF65
	Configuration Mode	Configuration from BPI Flash: <ul style="list-style-type: none"> •Master BPI (x16) Configuration from FPGA #2: <ul style="list-style-type: none"> •Master SelectMAP (x8, x16) •Slave SelectMAP (x8) •Master Serial •Slave Serial •Master SPI (x1, x2, x4)
	Clock	<ul style="list-style-type: none"> •System Clock 200MHz (Differential) •DDR3 Reference Clock 200MHz (Differential)
	User LED	10bit
	User Switch	DIP Switch 8bit / Push Switch 1bit
	User GPIO	<ul style="list-style-type: none"> •Header 10bit •SMA 2pairs (Differential, Clock Capable)
	DRAM	DDR3-800MHz SDRAM
	FMC	LPC (w/o GTX, 2.5V only)
	Measurement point	High side of VCCINT (Core)
FPGA #2	FPGA	Xilinx Spartan-6 XC6SLX45-2FG484C
	Configuration ROM	32Mbit BPI Flash Memory XCF32PVOG48C
	Clock	•System Clock 24MHz
	User LED	10bit
	User Switch	DIP Switch 8bit / Push Switch 1bit
	User GPIO	<ul style="list-style-type: none"> •Header 10bit •SMA 2pairs (Differential, Clock Capable)
	FMC	LPC (w/o GTX, 2.5V only)
	USB I/F	FTDI FT2232H (Channel A, Channel B)
FPGA Interconnect	78 pin (39 pairs)	
Rated board voltage	<ul style="list-style-type: none"> •5V ±5% •12V ±5% (for FMC) 	
Rated board current	<ul style="list-style-type: none"> •USB bus power : 0.75A (Protected by fuse) •External power input : 6A (Rated by switch) 	
Substrate	8 Layers, FR-4, 1.6t	
Dimensions	200mm × 150mm	

2. Operational Instructions

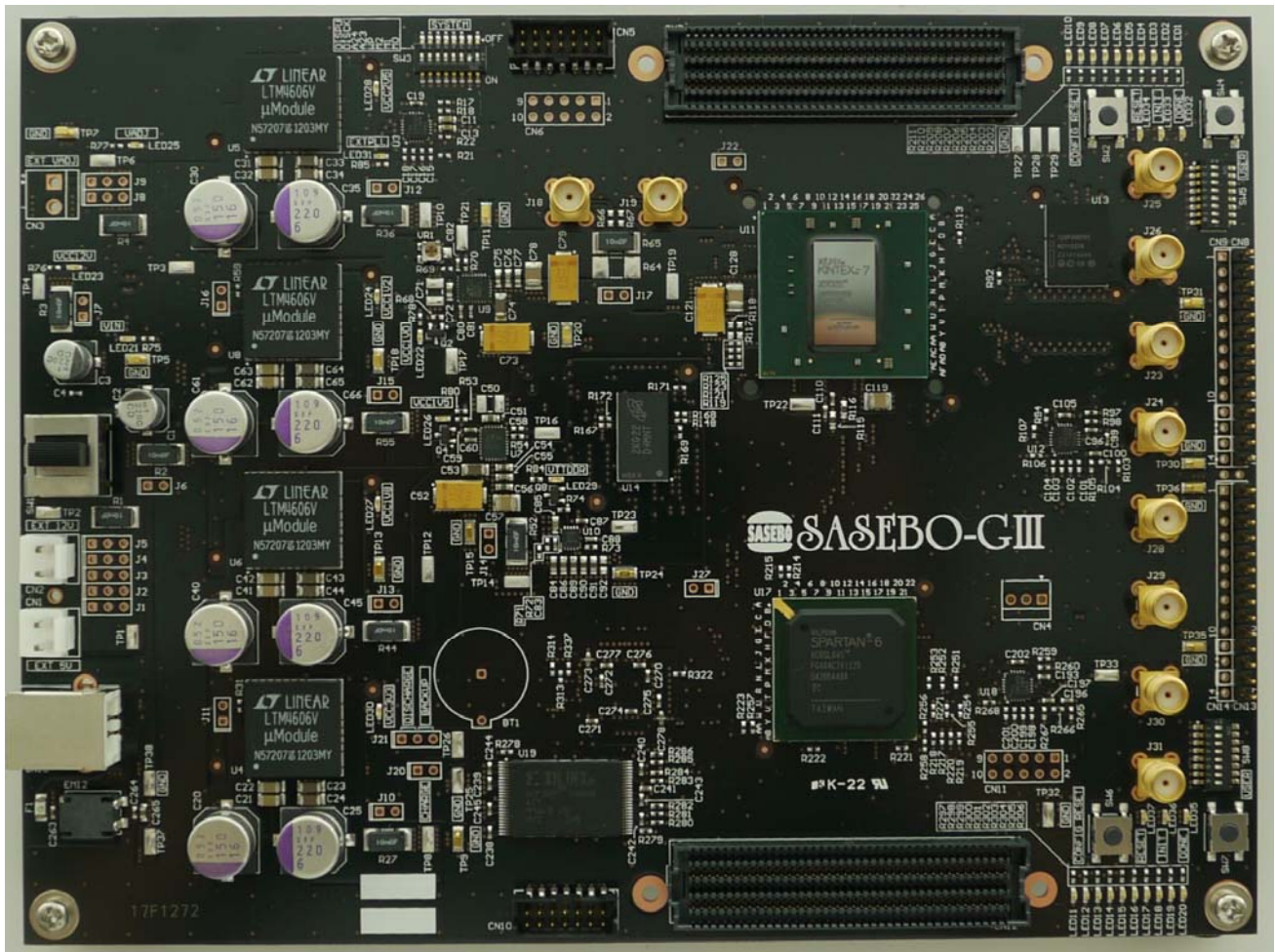

Figure 1 : SASEBO-GIII Top View

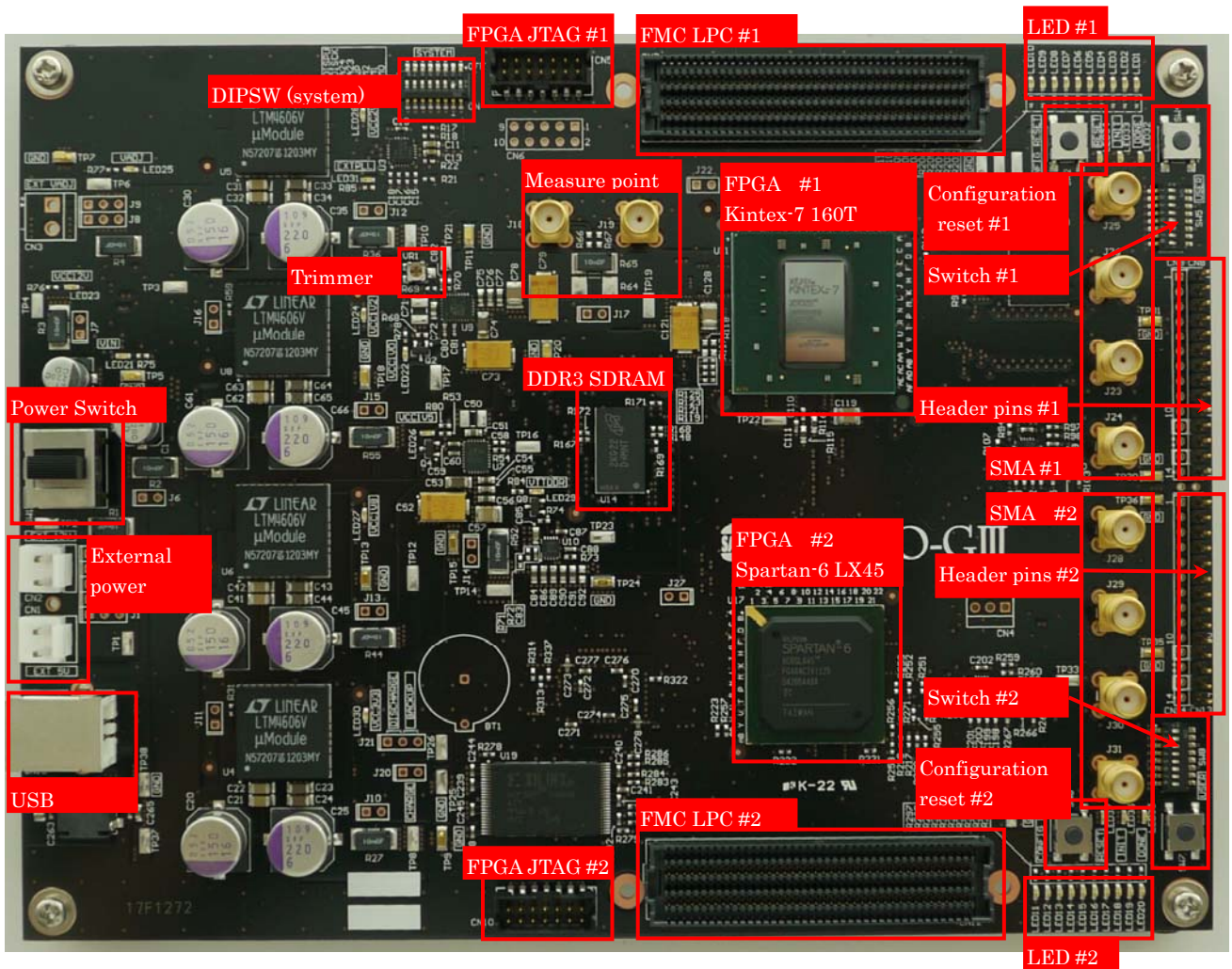

Figure 2 : SASEBO-GIII Board Functions

2.1. Power Circuit

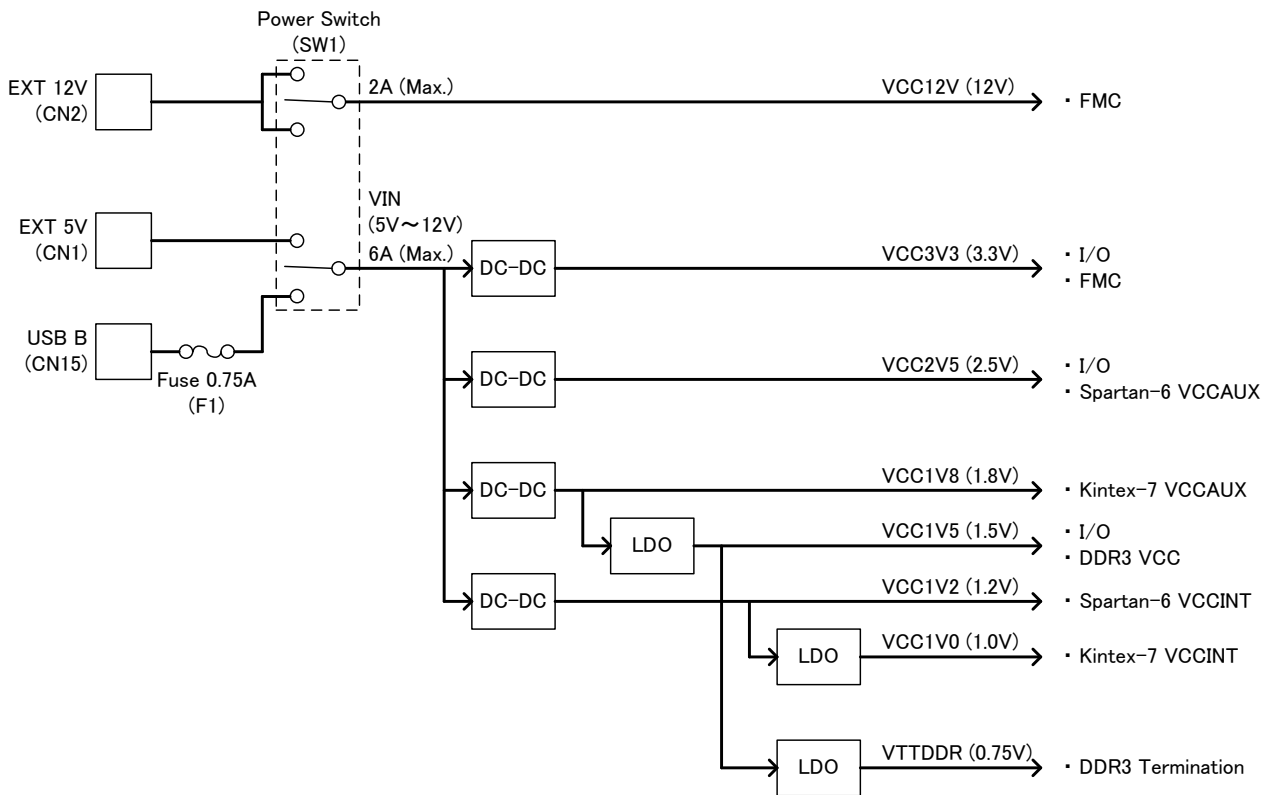

Figure 3 : Power Circuit

2.2. Voltage Calibration

The following voltage can be calibrated by trimmer.

Table 2 : Voltage Calibration Point

Trimmer	Voltage
VR1	FPGA Kintex-7 VCCINT (Core) 1.0V (0.9~1.1V)

2.3. Power-On Sequences

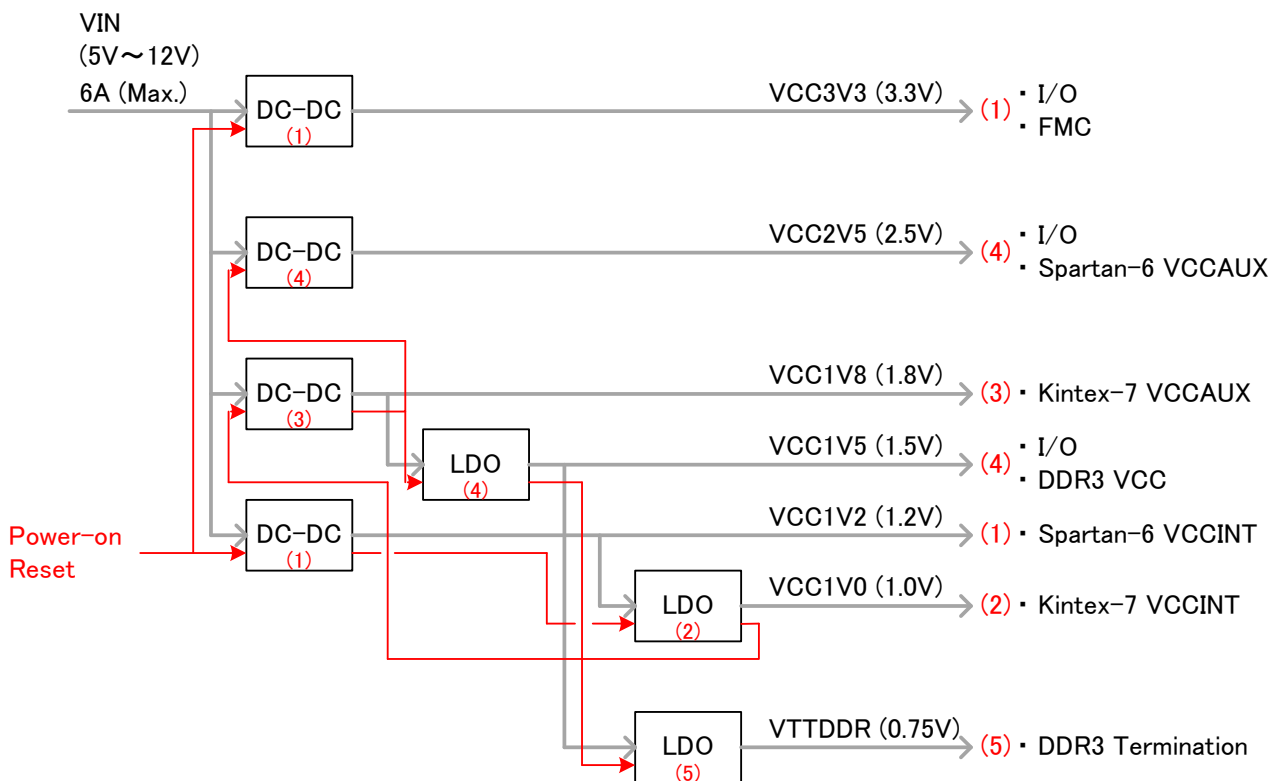

Figure 4 : Power-On Sequence

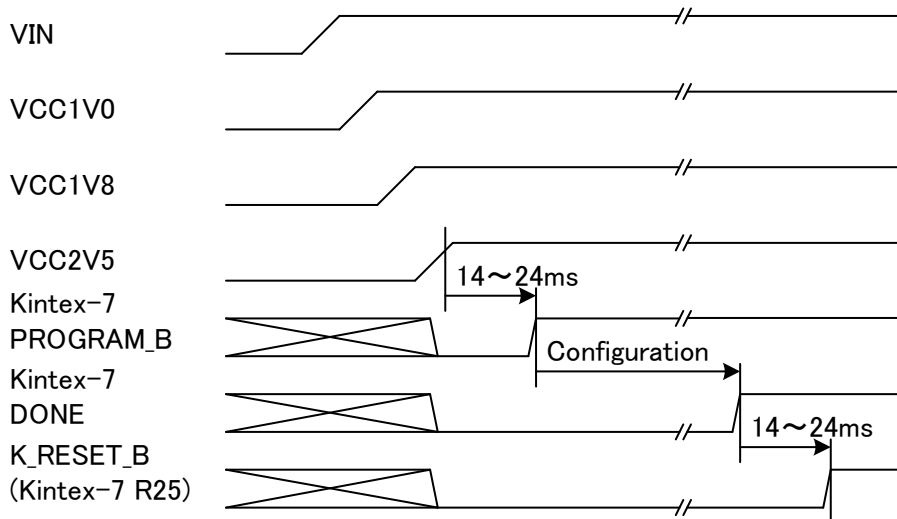

Figure 5 : Kintex-7 Reset Sequence

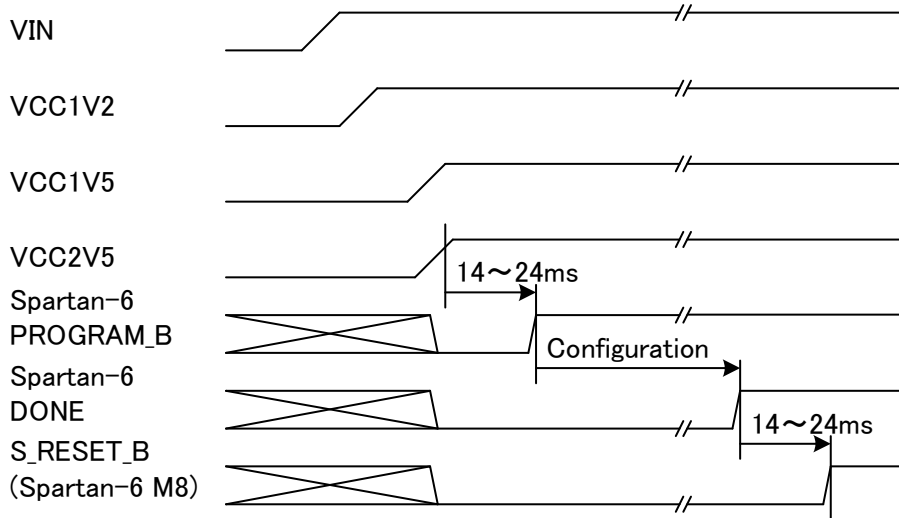

Figure 6 : Spartan-6 Reset Sequence

2.4. Configuration

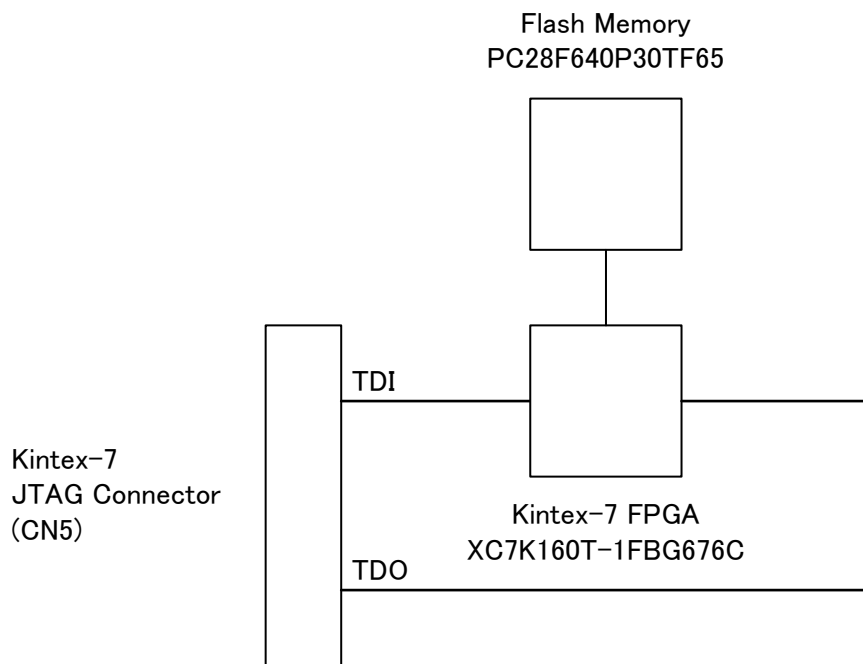

Figure 7 : Kintex-7 JTAG Chain

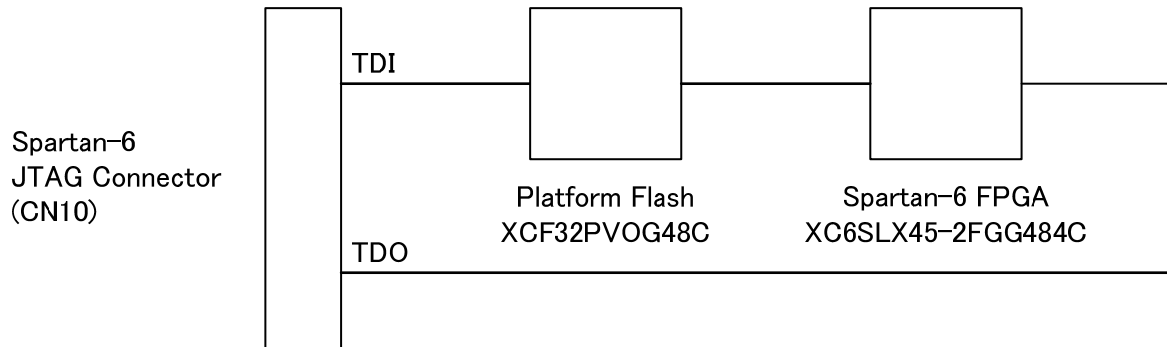

Figure 8 : Spartan-6 JTAG Chain

2.5. Clock System

(TBD)

2.6. Measurement Points

(TBD)

2.7. Connectors

Table 3 : Abstract of connectors

Connector	Function
CN1	External power supply(5.0V)
CN2	External power supply(12V) for FMC
CN3	Unused
CN4	Unused
CN5	Kintex-7 JTAG
CN6	Unused
CN7	Kintex-7 FMC LPC
CN8	Kintex-7 GPIO
CN9	Unused
CN10	Spartan-6 JTAG
CN11	Unused
CN12	Spartan-6 FMC LPC
CN13	Spartan-6 GPIO
CN14	Unused
CN15	USB

Table 4 : CN1, external power supply (5.0V)

Pin	Function
1 (▲)	VIN (5.0V)
2	GND

Table 5 : CN2, external power supply (12V)

Pin	Function
1 (▲)	VIN (12V)
2	GND

Table 6 : CN5 Kintex-7 JTAG

Pin	Function
1	GND
2	2.5V
3	GND
4	TMS

5	GND
6	TCK
7	GND
8	TDO
9	GND
10	TDI
11	GND
12	N.C.
13	GND
14	N.C.

Table 7 : CN8 Kintex-7 GPIO

Pin	Function
1	IO1
2	IO2
3	IO3
4	IO4
5	IO5
6	IO6
7	IO7
8	IO8
9	IO9
10	IO10
11	GND
12	2.5V
13	GND
14	VIN (12V)

Table 8 : CN10 Spartan-6 JTAG

Pin	Function
1	GND
2	2.5V
3	GND
4	TMS
5	GND

6	TCK
7	GND
8	TDO
9	GND
10	TDI
11	GND
12	N.C.
13	GND
14	N.C.

Table 9 : CN13 Spartan-6 GPIO

Pin	Function
1	IO1
2	IO2
3	IO3
4	IO4
5	IO5
6	IO6
7	IO7
8	IO8
9	IO9
10	IO10
11	GND
12	2.5V
13	GND
14	VIN (12V)

2.8. Switches

Table 10 : Abstract of switches

Switch	Function
SW1	Power
SW2	Kintex-7 Configuration Reset
SW3	System Settings
SW4	Kintex-7 User Push Switch
SW5	Kintex-7 User DIP Switch
SW6	Spartan-6 Configuration Reset
SW7	Spartan-6 User Push Switch
SW8	Spartan-6 User DIP Switch

Table 11 : SW1 Power

	Function
USB	VIN power supply via USB (CN15). 12V power supply for FMC via CN2.
OFF	Off.
EXT	VIN power supply via EXT5V (CN1). 12V power supply for FMC via CN2.

Table 12 : SW3 System Settings

Pin	Function	On	Off
1	M0	M0=1	M0=0 (*)
2	M1	M1=1 (*)	M1=0
3	M2	M2=1	M2=0 (*)
4	Kintex-7 BPI Flash Write Protect	Protected	Writable (*)
5	(Reserved)		(*)
6	(Reserved)		(*)
7	Kintex-7 Clock Inhibit	Oscillator Disable	Oscillator Enable (*)
8	Kintex-7 PUDC_B	Hi-Z	Pull-up (*)

(*) Default Settings

3. I/O Assignments

3.1. Kintex-7

Table 13 : Kintex-7 Clock

Signal Name	Kintex-7 (U11) Pin	Destination	Voltage
K_CLK_OSC0_HSTL_N	AC2	U15.5	1.5
K_CLK_OSC0_HSTL_P	AB2	U15.4	1.5
K_CLK_OSC1_HSTL_N	AA2	U16.5	1.5
K_CLK_OSC1_HSTL_P	AA3	U16.4	1.5
K_CLK_INH_B	J8	U15.1, U16.1	2.5

Table 14 : Kintex-7 Reset

Signal Name	Kintex-7 (U11) Pin	Destination	Voltage
K_RESET_B	R25	U12.16	2.5
K_WDT_WDI	P25	U12.20	2.5
K_WDT_WDO_B	AD11	U12.19	1.5

Table 15 : Kintex-7 Configuration

Signal Name	Kintex-7 (U11) Pin	Spartan-6 (U17) Pin	Flash (U13) Signal	Others	Volt.
K_CONF_A0	J23		A1		2.5
K_CONF_A1	K23		A2		2.5
K_CONF_A2	K22		A3		2.5
K_CONF_A3	L22		A4		2.5
K_CONF_A4	J25		A5		2.5
K_CONF_A5	J24		A6		2.5
K_CONF_A6	H22		A7		2.5
K_CONF_A7	H24		A8		2.5
K_CONF_A8	H23		A9		2.5
K_CONF_A9	G21		A10		2.5
K_CONF_A10	H21		A11		2.5
K_CONF_A11	H26		A12		2.5
K_CONF_A12	J26		A13		2.5
K_CONF_A13	E26		A14		2.5
K_CONF_A14	F25		A15		2.5
K_CONF_A15	G26		A16		2.5

K_CONF_A16	K17		A17		2.5
K_CONF_A17	K16		A18		2.5
K_CONF_A18	L20		A19		2.5
K_CONF_A19	J19		A20		2.5
K_CONF_A20	J18		A21		2.5
K_CONF_A21	J20		A22		2.5
K_CONF_A22	K20		A23		2.5
			A24	SW3.5	2.5
			A25	SW3.6	2.5
			A26	(N.C.)	2.5
			A27	(N.C.)	2.5
K_CONF_D0	B24	D1 (*)	D0		2.5
K_CONF_D1	A25	D2 (*)	D1		2.5
K_CONF_D2	B22	B1 (*)	D2		2.5
K_CONF_D3	A22	C3 (*)	D3		2.5
K_CONF_D4	A23	C4 (*)	D4		2.5
K_CONF_D5	A24	D3 (*)	D5		2.5
K_CONF_D6	D26	E4 (*)	D6		2.5
K_CONF_D7	C26	E5 (*)	D7		2.5
K_CONF_D8	C24	E3 (*)	D8		2.5
K_CONF_D9	D21	C1 (*)	D9		2.5
K_CONF_D10	C22	B2 (*)	D10		2.5
K_CONF_D11	B20	A2 (*)	D11		2.5
K_CONF_D12	A20	F3 (*)	D12		2.5
K_CONF_D13	E22	B3 (*)	D13		2.5
K_CONF_D14	C21	D5 (*)	D14		2.5
K_CONF_D15	B21	E6 (*)	D15		2.5
K_CONF_PROGRAM_B	P6	G3 (*)			2.5
K_CONF_INIT_B	G7	A4 (*)	/RST		2.5
K_CONF_DONE	J7	F5 (*)			2.5
K_CONF_CCLK	C8 (*)	J4 (*)	CLK (*)		2.5
K_CONF_PUDC_B	B25				2.5
K_CONF_EMCLK	B26	F2 (*)			2.5
K_CONF_FCS_B	C23	E1 (*)	/CE		2.5
K_CONF_FOE_B	M17		/OE		2.5
K_CONF_FWE_B	L18		/WE		2.5

K_CONF_RDWR_B	E25	G1 (*)			2.5
K_CONF_ADV_B	D20		/ADV		2.5
K_CONF_CSI_B	G25	H2 (*)			2.5
K_CONF_DOUT_CSO_B	D25	F1 (*)			2.5
			WAIT	(N.C.)	2.5
			/WP	SW3.4	2.5
K_M0				SW3.1	2.5
K_M1				SW3.2	2.5
K_M2				SW3.3	2.5
K_JTAG_TCK	L8			CN5.6	2.5
K_JTAG_TDI	R6			CN5.10	2.5
K_JTAG_TDO	R7			CN5.8	2.5
K_JTAG_TMS	N8			CN5.4	2.5

(*) : Small resistor (100Ω or 22Ω) is inserted.

Table 16 : Kintex-7 DDR3

Signal Name	Kintex-7 (U11) Pin	DDR3 (U13) Signal	Volt.
K_DDR3_A0	AE1	A0	1.5
K_DDR3_A1	AB6	A1	1.5
K_DDR3_A2	AE3	A2	1.5
K_DDR3_A3	AC6	A3	1.5
K_DDR3_A4	Y6	A4	1.5
K_DDR3_A5	AD4	A5	1.5
K_DDR3_A6	AA5	A6	1.5
K_DDR3_A7	AF3	A7	1.5
K_DDR3_A8	AB5	A8	1.5
K_DDR3_A9	AF2	A9	1.5
K_DDR3_A10	AD3	A10	1.5
K_DDR3_A11	AC4	A11	1.5
K_DDR3_A12	AD1	A12	1.5
K_DDR3_A13	AE2	A13	1.5
K_DDR3_A14	AC3	A14	1.5
K_DDR3_BA0	AF4	BA0	1.5
K_DDR3_BA1	Y5	BA1	1.5
K_DDR3_BA2	AD5	BA2	1.5
K_DDR3_CKE	U2	CKE	1.5

K_DDR3_CK_N	W5	CK#	1.5
K_DDR3_CK_P	W6	CK	1.5
K_DDR3_CS_B	AE5	CS#	1.5
K_DDR3_RAS_B	AE6	RAS#	1.5
K_DDR3_CAS_B	AD6	CAS#	1.5
K_DDR3_WE_B	AF5	WE#	1.5
K_DDR3_ODT	U1	ODT	1.5
K_DDR3_RESET_B	AB7	RESET#	1.5
K_DDR3_DQ0	AA9	DQ0	1.5
K_DDR3_DQ1	AD9	DQ1	1.5
K_DDR3_DQ2	AB9	DQ2	1.5
K_DDR3_DQ3	AF7	DQ3	1.5
K_DDR3_DQ4	AA8	DQ4	1.5
K_DDR3_DQ5	AA7	DQ5	1.5
K_DDR3_DQ6	AE7	DQ6	1.5
K_DDR3_DQ7	AC7	DQ7	1.5
K_DDR3_DQ8	V9	DQ8	1.5
K_DDR3_DQ9	Y10	DQ9	1.5
K_DDR3_DQ10	V8	DQ10	1.5
K_DDR3_DQ11	Y11	DQ11	1.5
K_DDR3_DQ12	Y8	DQ12	1.5
K_DDR3_DQ13	V11	DQ13	1.5
K_DDR3_DQ14	V7	DQ14	1.5
K_DDR3_DQ15	W11	DQ15	1.5
K_DDR3_DQS0_N	AD8	LDQS#	1.5
K_DDR3_DQS0_P	AC8	LDQS	1.5
K_DDR3_DQS1_N	W9	UDQS#	1.5
K_DDR3_DQS1_P	W10	UDQS	1.5
K_DDR3_DM0	AC9	LDM	1.5
K_DDR3_DM1	Y7	UDM	1.5

Table 17 : Kintex-7 Switch

Signal Name	Kintex-7 (U11) Pin	Destination	Volt.
K_DIPSW_0	J21	SW5.1	2.5
K_DIPSW_1	N19	SW5.2	2.5
K_DIPSW_2	M16	SW5.3	2.5

K_DIPSW_3	M20	SW5.4	2.5
K_DIPSW_4	L17	SW5.5	2.5
K_DIPSW_5	N24	SW5.6	2.5
K_DIPSW_6	K21	SW5.7	2.5
K_DIPSW_7	E21	SW5.8	2.5
K_PUSHSW	L23	SW4	2.5

Table 18 : Kintex-7 FMC

Signal Name	Kintex-7 (U11) Pin	CN7 Pin	Volt.
K_FMC_CLK0_M2C_N	E17	G7	2.5
K_FMC_CLK0_M2C_P	F17	G6	2.5
K_FMC_CLK1_M2C_N	D18	D9	2.5
K_FMC_CLK1_M2C_P	E18	D8	2.5
K_FMC_LA00_CC_N	F10	G7	2.5
K_FMC_LA00_CC_P	G11	G6	2.5
K_FMC_LA01_CC_N	D11	D9	2.5
K_FMC_LA01_CC_P	E11	D8	2.5
K_FMC_LA02_N	E16	H8	2.5
K_FMC_LA02_P	E15	H7	2.5
K_FMC_LA03_N	D13	G10	2.5
K_FMC_LA03_P	D14	G9	2.5
K_FMC_LA04_N	F20	H11	2.5
K_FMC_LA04_P	G19	H10	2.5
K_FMC_LA05_N	D16	D12	2.5
K_FMC_LA05_P	D15	D11	2.5
K_FMC_LA06_N	B19	C11	2.5
K_FMC_LA06_P	C19	C10	2.5
K_FMC_LA07_N	A17	H14	2.5
K_FMC_LA07_P	B17	H13	2.5
K_FMC_LA08_N	E20	G13	2.5
K_FMC_LA08_P	F19	G12	2.5
K_FMC_LA09_N	A19	D15	2.5
K_FMC_LA09_P	A18	D14	2.5
K_FMC_LA10_N	C18	C15	2.5
K_FMC_LA10_P	C17	C14	2.5
K_FMC_LA11_N	G16	H17	2.5

K_FMC_LA11_P	H16	H16	2.5
K_FMC_LA12_N	B16	G16	2.5
K_FMC_LA12_P	C16	G15	2.5
K_FMC_LA13_N	A15	D18	2.5
K_FMC_LA13_P	B15	D17	2.5
K_FMC_LA14_N	F15	C19	2.5
K_FMC_LA14_P	G15	C18	2.5
K_FMC_LA15_N	A14	H20	2.5
K_FMC_LA15_P	B14	H19	2.5
K_FMC_LA16_N	E12	G19	2.5
K_FMC_LA16_P	E13	G18	2.5
K_FMC_LA17_CC_N	C11	D21	2.5
K_FMC_LA17_CC_P	C12	D20	2.5
K_FMC_LA18_CC_N	D10	C23	2.5
K_FMC_LA18_CC_P	E10	C22	2.5
K_FMC_LA19_N	D8	H23	2.5
K_FMC_LA19_P	D9	H22	2.5
K_FMC_LA20_N	G9	G22	2.5
K_FMC_LA20_P	G10	G21	2.5
K_FMC_LA21_N	A12	H26	2.5
K_FMC_LA21_P	A13	H25	2.5
K_FMC_LA22_N	F8	G25	2.5
K_FMC_LA22_P	F9	G24	2.5
K_FMC_LA23_N	J16	D24	2.5
K_FMC_LA23_P	J15	D23	2.5
K_FMC_LA24_N	H8	H29	2.5
K_FMC_LA24_P	H9	H28	2.5
K_FMC_LA25_N	F13	G28	2.5
K_FMC_LA25_P	F14	G27	2.5
K_FMC_LA26_N	H13	D27	2.5
K_FMC_LA26_P	J13	D26	2.5
K_FMC_LA27_N	B11	C27	2.5
K_FMC_LA27_P	B12	C26	2.5
K_FMC_LA28_N	B9	H32	2.5
K_FMC_LA28_P	C9	H31	2.5
K_FMC_LA29_N	A8	G31	2.5

K_FMC_LA29_P	A9	G30	2.5
K_FMC_LA30_N	F12	H35	2.5
K_FMC_LA30_P	G12	H34	2.5
K_FMC_LA31_N	J10	G34	2.5
K_FMC_LA31_P	J11	G33	2.5
K_FMC_LA32_N	A10	H38	2.5
K_FMC_LA32_P	B10	H37	2.5
K_FMC_LA33_N	G14	G37	2.5
K_FMC_LA33_P	H14	G36	2.5
K_FMC_PG_EN	U16	D1	2.5
K_FMC_PRSENT_B	J14	H2	2.5
K_FMC_SCL_2V5	C14	C30	2.5
K_FMC_SDA_2V5	C13	C31	2.5

Table 19 : Kintex-7 GPIO

Signal Name	Kintex-7 (U11) Pin	Destination	Volt.
K_HEADER_0	D19	CN8.1	2.5
K_HEADER_1	N17	CN8.2	2.5
K_HEADER_2	N16	CN8.3	2.5
K_HEADER_3	P24	CN8.4	2.5
K_HEADER_4_N	E23 (CC)	CN8.5	2.5
K_HEADER_4_P	F22 (CC)	CN8.6	2.5
K_HEADER_6_N	F23 (CC)	CN8.7	2.5
K_HEADER_6_P	G22 (CC)	CN8.8	2.5
K_HEADER_8_N	F24 (CC)	CN8.9	2.5
K_HEADER_8_P	G24 (CC)	CN8.10	2.5
K_CLK_EXT0_N	H18 (CC)	J24	2.5
K_CLK_EXT0_P	H17 (CC)	J23	2.5
K_CLK_EXT1_N	F18 (CC)	J26	2.5
K_CLK_EXT1_P	G17 (CC)	J25	2.5
K_RSPIO_0_N	D24 (CC)	TP29	2.5
K_RSPIO_0_P	D23 (CC)	TP28	2.5

(CC): Clock Capable pin

Table 20 : Kintex-7 LED

Signal Name	Kintex-7 (U11) Pin	Destination	Volt.
K_LED_0	G20	LED1	2.5

K_LED_1	L19	LED2	2.5
K_LED_2	K18	LED3	2.5
K_LED_3	H19	LED4	2.5
K_LED_4	K15	LED5	2.5
K_LED_5	P16	LED6	2.5
K_LED_6	T19	LED7	2.5
K_LED_7	T18	LED8	2.5
K_LED_8	H12	LED9	2.5
K_LED_9	H11	LED10	2.5

3.2. Spartan-6

Table 21 : Spartan-6 Clock

Signal Name	Spartan-6 (U17) Pin	Destination Pin	Volt.
S_CLK_OSC	M3	U20.3	2.5
S_CLK_INH_B	M1	U20.1	2.5

Table 22 : Spartan-6 Reset

Signal Name	Spartan-6 (U17) Pin	Destination Pin	Volt.
S_RESET_B	M8	U18.16	2.5
S_WDT_WDI	R9	U18.20	2.5
S_WDT_WDO_B	R22	U18.19	1.5

Table 23 : Spartan-6 Configuration

Signal Name	Spartan-6 (U17) Pin	Flash (U19)	Volt.
S_CONF_BUSY	T20		2.5
S_CONF_CCLK	Y21	CLK	2.5
S_CONF_CSI_B	AB20		2.5
S_CONF_CSO_B	T5		2.5
S_CONF_D0	AA20	D0	2.5
S_CONF_D1	U14	D1	2.5
S_CONF_D2	U13	D2	2.5
S_CONF_D3	AA6	D3	2.5
S_CONF_D4	AB6	D4	2.5
S_CONF_D5	W4	D5	2.5
S_CONF_D6	Y4	D6	2.5
S_CONF_D7	Y7	D7	2.5
S_CONF_DONE	Y22	/CE	2.5

S_CONF_HSWAPEN	A3		2.5
S_CONF_INIT_B	T6	OE, /RESET	2.5
S_CONF_M0	AA22		2.5
S_CONF_M1	U15		2.5
S_CONF_PROGRAM_B	AA1	/CF	2.5
S_CONF_RDWR_B	AB7		2.5

Table 24 : Spartan-6 Switch

Signal Name	Spartan-6 (U17) Pin	Destination	Volt.
S_DIPSW_0	R20	SW8.1	1.5
S_DIPSW_1	T21	SW8.2	1.5
S_DIPSW_2	U20	SW8.3	1.5
S_DIPSW_3	V21	SW8.4	1.5
S_DIPSW_4	W22	SW8.5	1.5
S_DIPSW_5	V22	SW8.6	1.5
S_DIPSW_6	U22	SW8.7	1.5
S_DIPSW_7	T22	SW8.8	1.5
S_PUSHSW	M19	SW7	1.5

Table 25 : Spartan-6 FMC

Signal Name	Spartan-6 (U17) Pin	CN12 Signal	Volt.
S_FMC_CLK0_M2C_N	K4	H5	2.5
S_FMC_CLK0_M2C_P	K5	H4	2.5
S_FMC_CLK1_M2C_N	J1	G3	2.5
S_FMC_CLK1_M2C_P	J3	G2	2.5
S_FMC_LA00_CC_N	AB11	G7	2.5
S_FMC_LA00_CC_P	Y11	G6	2.5
S_FMC_LA01_CC_N	Y12	D9	2.5
S_FMC_LA01_CC_P	W12	D8	2.5
S_FMC_LA02_N	AB2	H8	2.5
S_FMC_LA02_P	AA2	H7	2.5
S_FMC_LA03_N	AB3	G10	2.5
S_FMC_LA03_P	Y3	G9	2.5
S_FMC_LA04_N	AB4	H11	2.5
S_FMC_LA04_P	AA4	H10	2.5
S_FMC_LA05_N	Y8	D12	2.5

S_FMC_LA05_P	W9	D11	2.5
S_FMC_LA06_N	V9	C11	2.5
S_FMC_LA06_P	U9	C10	2.5
S_FMC_LA07_N	AB8	H14	2.5
S_FMC_LA07_P	AA8	H13	2.5
S_FMC_LA08_N	V5	G13	2.5
S_FMC_LA08_P	U6	G12	2.5
S_FMC_LA09_N	AB9	D15	2.5
S_FMC_LA09_P	Y9	D14	2.5
S_FMC_LA10_N	Y10	C15	2.5
S_FMC_LA10_P	W10	C14	2.5
S_FMC_LA11_N	V7	H17	2.5
S_FMC_LA11_P	W8	H16	2.5
S_FMC_LA12_N	AB10	G16	2.5
S_FMC_LA12_P	AA10	G15	2.5
S_FMC_LA13_N	T11	D18	2.5
S_FMC_LA13_P	R11	D17	2.5
S_FMC_LA14_N	W11	C19	2.5
S_FMC_LA14_P	V11	C18	2.5
S_FMC_LA15_N	R13	H20	2.5
S_FMC_LA15_P	T14	H19	2.5
S_FMC_LA16_N	W13	G19	2.5
S_FMC_LA16_P	V13	G18	2.5
S_FMC_LA17_CC_N	AB12	D21	2.5
S_FMC_LA17_CC_P	AA12	D20	2.5
S_FMC_LA18_CC_N	AB13	C23	2.5
S_FMC_LA18_CC_P	Y13	C22	2.5
S_FMC_LA19_N	U16	H23	2.5
S_FMC_LA19_P	U17	H22	2.5
S_FMC_LA20_N	T15	G22	2.5
S_FMC_LA20_P	T16	G21	2.5
S_FMC_LA21_N	AB15	H26	2.5
S_FMC_LA21_P	Y15	H25	2.5
S_FMC_LA22_N	AB14	G25	2.5
S_FMC_LA22_P	AA14	G24	2.5
S_FMC_LA23_N	Y14	D24	2.5

S_FMC_LA23_P	W14	D23	2.5
S_FMC_LA24_N	AB17	H29	2.5
S_FMC_LA24_P	Y17	H28	2.5
S_FMC_LA25_N	AB16	G28	2.5
S_FMC_LA25_P	AA16	G27	2.5
S_FMC_LA26_N	W17	D27	2.5
S_FMC_LA26_P	V17	D26	2.5
S_FMC_LA27_N	T17	C27	2.5
S_FMC_LA27_P	T18	C26	2.5
S_FMC_LA28_N	Y18	H32	2.5
S_FMC_LA28_P	W18	H31	2.5
S_FMC_LA29_N	R15	G31	2.5
S_FMC_LA29_P	R16	G30	2.5
S_FMC_LA30_N	AB19	H35	2.5
S_FMC_LA30_P	Y19	H34	2.5
S_FMC_LA31_N	AB18	G34	2.5
S_FMC_LA31_P	AA18	G33	2.5
S_FMC_LA32_N	AB21	H38	2.5
S_FMC_LA32_P	AA21	H37	2.5
S_FMC_LA33_N	V18	G37	2.5
S_FMC_LA33_P	V19	G36	2.5
S_FMC_PG_EN	R8	D1	2.5
S_FMC_PRSNT_B	Y2	H2	2.5
S_FMC_SCL	V15	C30	2.5
S_FMC_SDA	T7	C31	2.5

Table 26 : Spartan-6 FTDI

Signal Name	Spartan-6 (U17) Pin	FTDI (U21) Pin	Volt.
S_FTDI_ACBUS0_RXF_B	H1	26	2.5
S_FTDI_ACBUS1_TXE_B	P5	27	2.5
S_FTDI_ACBUS2_RD_B	L6	28	2.5
S_FTDI_ACBUS3_WR_B	M5	29	2.5
S_FTDI_ACBUS4_SIWUA	L3	30	2.5
S_FTDI_ACBUS5_CLKOUT	K3	32	2.5
S_FTDI_ACBUS6_OE_B	L1	33	2.5
S_FTDI_ACBUS7	M6	34	2.5

S_FTDI_ADBUS0_D0	N4	16	2.5
S_FTDI_ADBUS1_D1	H4	17	2.5
S_FTDI_ADBUS2_D2	M2	18	2.5
S_FTDI_ADBUS3_D3	H3	19	2.5
S_FTDI_ADBUS4_D4	K6	21	2.5
S_FTDI_ADBUS5_D5	M4	22	2.5
S_FTDI_ADBUS6_D6	K2	23	2.5
S_FTDI_ADBUS7_D7	K1	24	2.5
S_FTDI_BCBUS0_RXF_B	T2	48	2.5
S_FTDI_BCBUS1_TXE_B	U1	52	2.5
S_FTDI_BCBUS2_RD_B	V2	53	2.5
S_FTDI_BCBUS3_WR_B	T3	54	2.5
S_FTDI_BCBUS4_SIWUB	V1	55	2.5
S_FTDI_BCBUS5	U4	57	2.5
S_FTDI_BCBUS6	T1	58	2.5
S_FTDI_BCBUS7_PWRSV	V3	59	2.5
S_FTDI_BDBUS0_D0	P4	38	2.5
S_FTDI_BDBUS1_D1	N1	39	2.5
S_FTDI_BDBUS2_D2	P1	40	2.5
S_FTDI_BDBUS3_D3	P2	41	2.5
S_FTDI_BDBUS4_D4	R4	43	2.5
S_FTDI_BDBUS5_D5	R1	44	2.5
S_FTDI_BDBUS6_D6	R3	45	2.5
S_FTDI_BDBUS7_D7	T4	46	2.5
S_FTDI_PWREN_B	U3	60	2.5
S_FTDI_RESET_B	P3	14	2.5
S_FTDI_SUSPEND_B	N3	36	2.5

Table 27 : Spartan-6 GPIO

Signal Name	Spartan-6 (U17) Pin	Destination	Volt.
S_HEADER_0	F7	CN13.1	2.5
S_HEADER_1	G4	CN13.2	2.5
S_HEADER_2	G6	CN13.3	2.5
S_HEADER_3	G7	CN13.4	2.5
S_HEADER_4_N	A18	CN13.5	2.5
S_HEADER_4_P	B18	CN13.6	2.5

S_HEADER_6_N	H8	CN13.7	2.5
S_HEADER_6_P	J7	CN13.8	2.5
S_HEADER_8_N	K8	CN13.9	2.5
S_HEADER_8_P	K7	CN13.10	2.5
S_CLK_EXT0_N	C12 (CC)	J29	2.5
S_CLK_EXT0_P	D11 (CC)	J28	2.5
S_CLK_EXT1_N	A11 (CC)	J31	2.5
S_CLK_EXT1_P	C11 (CC)	J30	2.5
K_RSVIO_0	N7	TP33	2.5

(CC): Clock Capable pin

Table 28 : Spartan-6 LED

Signal Name	Spartan-6 (U17) Pin	Destination	Volt.
S_LED_0	N22	LED11	1.5
S_LED_1	N20	LED12	1.5
S_LED_2	P20	LED13	1.5
S_LED_3	P22	LED14	1.5
S_LED_4	P21	LED15	1.5
S_LED_5	H5	LED16	2.5
S_LED_6	H6	LED17	2.5
S_LED_7	J6	LED18	2.5
S_LED_8	N6	LED19	2.5
S_LED_9	M7	LED20	2.5

3.3. FPGA Interconnects

Table 29 : FPGA Interconnects

Signal Name	Kintex-7 (U11)	Spartan-6 (U17)	Voltage
KS_HPIC_00_N	W4	D22	1.5
KS_HPIC_00_P	V4	D21	1.5
KS_HPIC_01_N	V1	B20	1.5
KS_HPIC_01_P	V2	C19	1.5
KS_HPIC_02_N	Y1	B22	1.5
KS_HPIC_02_P	W1	B21	1.5
KS_HPIC_03_N	AC1	D20	1.5
KS_HPIC_03_P	AB1	D19	1.5
KS_HPIC_04_N	Y2	C22	1.5
KS_HPIC_04_P	Y3	C20	1.5

KS_HPIC_05_N	V6	F19	1.5
KS_HPIC_05_P	U7	F18	1.5
KS_HPIC_06_N	W3	A21	1.5
KS_HPIC_06_P	V3	A20	1.5
KS_HPIC_07_N	AF9	F22	1.5
KS_HPIC_07_P	AF10	F21	1.5
KS_HPIC_08_N	AD13	K19 (CC)	1.5
KS_HPIC_08_P	AC13	K20 (CC)	1.5
KS_HPIC_09_N	AF12	H22 (CC)	1.5
KS_HPIC_09_P	AE12	H21 (CC)	1.5
KS_HPIC_10_N	U5	L19 (CC)	1.5
KS_HPIC_10_P	U6	M20 (CC)	1.5
KS_HPIC_11_N	AF13	J22 (CC)	1.5
KS_HPIC_11_P	AE13	J20 (CC)	1.5
KS_HPIC_12_N	AB10 (CC)	J19	1.5
KS_HPIC_12_P	AA10 (CC)	H20	1.5
KS_HPIC_13_N	AC12 (CC)	L22	1.5
KS_HPIC_13_P	AB12 (CC)	L20	1.5
KS_HPIC_14_N	AB4 (CC)	E22	1.5
KS_HPIC_14_P	AA4 (CC)	E20	1.5
KS_HPIC_15_N	AF8	F20	1.5
KS_HPIC_15_P	AE8	G19	1.5
KS_HPIC_16_N	AE10	G22	1.5
KS_HPIC_16_P	AD10	G20	1.5
KS_HPIC_17_N	Y12	H18	1.5
KS_HPIC_17_P	Y13	H19	1.5
KS_HPIC_18_N	AA12	M22	1.5
KS_HPIC_18_P	AA13	M21	1.5
KS_HPIC_CLK_N	AC11 (CC)	K22	1.5
KS_HPIC_CLK_P	AB11 (CC)	K21	1.5
KS_HRIC_00_N	T23	C8	2.5
KS_HRIC_00_P	T22	D9	2.5
KS_HRIC_01_N	L24	A15	2.5
KS_HRIC_01_P	M24	C15	2.5
KS_HRIC_02_N	K26	D17	2.5
KS_HRIC_02_P	K25	E16	2.5

KS_HRIC_03_N	P26	A14	2.5
KS_HRIC_03_P	R26	B14	2.5
KS_HRIC_04_N	L25	A17	2.5
KS_HRIC_04_P	M25	C17	2.5
KS_HRIC_05_N	T17	D8	2.5
KS_HRIC_05_P	U17	D7	2.5
KS_HRIC_06_N	M26	A16	2.5
KS_HRIC_06_P	N26	B16	2.5
KS_HRIC_07_N	R17	A6	2.5
KS_HRIC_07_P	R16	B6	2.5
KS_HRIC_08_N	R20	A10 (CC)	2.5
KS_HRIC_08_P	T20	B10 (CC)	2.5
KS_HRIC_09_N	R23 (CC)	A12 (CC)	2.5
KS_HRIC_09_P	R22 (CC)	B12 (CC)	2.5
KS_HRIC_10_N	M22	A7	2.5
KS_HRIC_10_P	M21	C7	2.5
KS_HRIC_11_N	T25	C14	2.5
KS_HRIC_11_P	T24	D14	2.5
KS_HRIC_12_N	N23 (CC)	C16	2.5
KS_HRIC_12_P	P23 (CC)	D15	2.5
KS_HRIC_13_N	N22 (CC)	A13	2.5
KS_HRIC_13_P	N21 (CC)	C13	2.5
KS_HRIC_14_N	P21 (CC)	C10	2.5
KS_HRIC_14_P	R21 (CC)	D10	2.5
KS_HRIC_15_N	M19	C6	2.5
KS_HRIC_15_P	N18	D6	2.5
KS_HRIC_16_N	P18	A5	2.5
KS_HRIC_16_P	R18	C5	2.5
KS_HRIC_17_N	U20	A8	2.5
KS_HRIC_17_P	U19	B8	2.5
KS_HRIC_18_N	P20	A9	2.5
KS_HRIC_18_P	P19	C9	2.5

(CC) Clock Capable pin

4. Parts List, Schematic, and Board Layout

Table 30 : Parts List

Description	Part Number	Maker	Reference Designator	Spec.
Capacitor	UCD1C221MCL1GS	Nichicon	C1, C3	220u
Capacitor	GRM155B31C104KA87D	Murata	C2, C4, C10, C19, C27, C37, C47, C68, C87, C94, C105, C110, C111, C144, C146, C147, C149, C150, C151, C152, C153, C154, C155, C156, C157, C158, C159, C160, C161, C162, C163, C164, C165, C166, C167, C168, C169, C170, C171, C172, C173, C174, C202, C238, C239, C240, C241, C242, C243, C244, C245, C257, C263, C264, C270, C271, C272, C274, C275, C276, C277, C283	0.1u
Capacitor	LMK107BJ106MALTD	Taiyo Yuden	C6, C51, C56, C72, C77, C84, C86, C89, C90, C91, C145, C148, C175, C189, C192, C246, C247, C262, C265	10u
Capacitor	NFM18PC105R0J3	Murata	C7, C8, C188, C191, C261, C267, C269, C273, C278	1u
Capacitor	GRM155B11E103KA01D	Murata	C9, C60, C81, C114, C115, C116, C117, C187, C190, C260	0.01u
Capacitor	GRM188B31E105KA75D	Murata	C11, C12, C13, C14, C183, C184, C255, C256	1u
Capacitor	16SVP150M	SANYO	C20, C30, C40, C61	150u
Capacitor	GRM31CR71C106KAC7L	Murata	C21, C22, C28, C31, C32, C38, C41, C42, C48, C62, C63, C69	10u
Capacitor	C3216JB0J476M	TDK	C23, C24, C33, C34, C43, C44, C53, C64, C65, C74	47u
Capacitor	6SVP220M	SANYO	C25, C35, C45, C66	220u
Capacitor	GRM1552C1H101JZ01D	Murata	C29, C39, C49, C70	100p
Capacitor	T520V337M2R5ATE025	Kemet	C52, C73, C79, C120, C121, C122	330u
Capacitor	EMK107BJ225KA-T	Taiyo Yuden	C54, C75	2.2u
Capacitor	GRM188R60J475ME19D	Murata	C55, C76, C85, C123, C124, C125, C126, C127, C129, C130, C131, C133, C134, C137, C138, C139, C141, C205, C209, C214, C220, C228, C229, C236, C266,	4.7u

			C268	
Capacitor	GRM32ER60J107ME20L	Murata	C57, C78, C106, C107, C108, C109, C112, C113, C118, C119, C128, C132, C204, C208, C213, C219, C230, C237	100u
Capacitor	GRM155B11H102KA01D	Murata	C59, C80, C82, C83, C96, C97, C98, C99, C100, C193, C194, C195, C196, C197	1000p
Capacitor	GRM1552C1H100JZ01D	Murata	C88	10p
Capacitor	T520B476M006ATE070	Kemet	C95, C135, C136, C140	47u
Capacitor	GRM155B31A105KE15D	Murata	C176, C177, C178, C179, C180, C181, C182, C185, C186, C248, C249, C250, C251, C252, C253, C254, C258, C259	1u
Capacitor	GRM155R60J474KE19D	Murata	C206, C207, C210, C211, C212, C215, C216, C217, C218, C221, C222, C223, C224, C225, C226, C227, C231, C232	0.47u
Capacitor	GRM1552C1H220JZ01D	Murata	C281, C282	22p
Connector	B2P-VH(LF)(SN)	JST	CN1, CN2	
Connector	87832-1420	Molex	CN5, CN10	
Connector	ASP-134603-01	Samtec	CN7, CN12	
Header	TSW-114-07-L-S	Samtec	CN8, CN13	
Connector	XM7B-0442	Omron	CN15	
EMI Filter	DLW21HN900SQ2	Murata	EMI1	
EMI Filter	ACM90V-701-2PL-TL00	TDK	EMI2	
Fuse	0437 .750WR	Littlefuse	F1	0.75A
SMA Jack	901-144	Amphenol	J18, J19, J23, J24, J25, J26, J28, J29, J30, J31	
Inductor	BLM18PG221SN1	Murata	L1, L3, L4, L5, L6, L7, L8, L9, L10	
Resistor	MCR01MZPJ000	Rohm	L2, R324	0
LED	SML-310MTT8	Rohm	LED1, LED2, LED3, LED4, LED5, LED6, LED7, LED8, LED9, LED10, LED11, LED12, LED13, LED14, LED15, LED16, LED17, LED18, LED19, LED20, LED21, LED22, LED23, LED24, LED25, LED26, LED27, LED28, LED29, LED30, LED31, LED32, LED33, LED34, LED35, LED36, LED37	
FET	NDS331N	FAIRCHILD	Q2, Q3, Q4, Q5, Q6, Q7, Q8, Q9, Q12, Q13, Q14, Q15, Q18, Q19, Q20, Q21, Q22	

FET	NDS332P	FAIRCHILD	Q10, Q11, Q16, Q17	
Resistor	UR73D3ATTP10L0F	KOA	R1, R2, R3, R4, R27, R36, R44, R52, R55, R65	10m
Resistor	MCR01MZPF1002	Rohm	R6, R106, R136, R137, R139, R199, R268, R272, R273, R275, R294, R316, R318, R319	10k
Resistor	ERJ2RKF6192X	Panasonic	R10	61.9k
Resistor	MCR01MZPF4702	Rohm	R11, R12	47k
Resistor	MCR01MZPJ000	Rohm	R13, R14, R107, R135, R173, R174, R175, R176, R177, R178, R179, R180, R181, R182, R183, R184, R185, R186, R187, R188, R189, R190, R191, R192, R215, R278, R320, R323, R325, R326, R327	0
Resistor	ERJ2RKF6813X	Panasonic	R17	681k
Resistor	ERJ2RKF1023X	Panasonic	R18, R20, R24, R100, R102, R262, R264	102k
Resistor	ERJ2RKF3243X	Panasonic	R19, R97, R99, R101, R259, R261	324k
Resistor	ERJ2RKF1913X	Panasonic	R21	191k
Resistor	ERJ2RKF1073X	Panasonic	R22	107k
Resistor	MCR01MZPF1303	Rohm	R23	130k
Resistor	MCR01MZPF1003	Rohm	R25, R31, R35, R43, R51, R59, R63, R74	100k
Resistor	MCR01MZPF2202	Rohm	R26, R108, R109, R269, R270, R321, R322	22k
Resistor	ERJ2RKF3923X	Panasonic	R33, R41, R49, R61	392k
Resistor	ERJ2RKF1332X	Panasonic	R34	13.3k
Resistor	ERJ2RKF1912X	Panasonic	R42	19.1k
Resistor	ERJ2RKF3012X	Panasonic	R50	30.1k
Resistor	MCR01MZPF5102	Rohm	R53, R68	51k
Resistor	MCR01MZPF1001	Rohm	R54, R70	1.00k
Resistor	ERJ2RKF6042X	Panasonic	R62	60.4k
Resistor	MCR01MZPF102	Rohm	R71, R72	10.0k
Resistor	MCR01MZPF10R0	Rohm	R73	10
Resistor	MCR01MZPF1001	Rohm	R75, R91, R93, R112, R113, R141, R142, R212, R218, R220, R221, R222, R223, R307, R314	1k
Resistor	MCR01MZPF3301	Rohm	R76	3.3k
Resistor	RK73B1ETTP151J	KOA	R77, R86, R87, R88, R202, R203, R204, R205, R206, R207, R208, R209, R210, R211, R248, R249, R250, R297, R298,	150

			R299, R300, R301, R302, R303, R304, R305, R306	
Resistor			R78, R79, R80, R81, R82, R83, R84, R85	560
Resistor	RK73B1ETTP331J	KOA	R92, R140, R256, R308	330
Resistor	MCR01MZPF4701	Rohm	R94, R130, R131, R132, R133, R134, R167, R169, R171, R198, R213, R257, R293, R309	4.7k
Resistor	MCR01MZPF22R0	Rohm	R95, R96, R224, R228, R279, R280, R281, R282, R283, R284, R285, R286	22
Resistor	ERJ2RKF6812X	Panasonic	R98, R260	68.1k
Resistor	ERJ2RKF2103X	Panasonic	R103	210k
Resistor	ERJ2RKF2052X	Panasonic	R104	20.5k
Resistor	ERJ2RKF1373X	Panasonic	R105	137k
Resistor	MCR03EZPFX1000	Rohm	R110, R111, R115, R116, R276, R277	100
Resistor	MCR01MZPF1000	Rohm	R119, R120, R121, R122, R123, R124, R125, R126, R170	100
Resistor	ERJ2RKF49R9X	Panasonic	R143, R144, R145, R146, R147, R148, R149, R150, R151, R152, R153, R154, R155, R156, R157, R158, R159, R160, R161, R162, R163, R164, R165, R166	49.9
Resistor	MCR01MZPF2400	Rohm	R172	240
Resistor	MCR03EZPJ101	Rohm	R216, R225, R226, R227, R229, R230, R231, R232, R233, R234, R235, R236, R237, R238, R239, R240, R241, R242, R243, R244, R245, R246, R247	100
Resistor	ERJ2RKF2553X	Panasonic	R263	255k
Resistor	ERJ2RKF2263X	Panasonic	R265	226k
Resistor	ERJ2RKF1622X	Panasonic	R266	16.2k
Resistor	MCR01MZPF1103	Rohm	R267	110k
Resistor	MCR18EZPJ000	Rohm	R310	0
Resistor	MCR01MZPF1202	Rohm	R315	12.0k
Resistor	MCR01MZPF2201	Rohm	R317	2.2k
Resistor Array	MNR04M0APJ223	Rohm	RA1, RA7, RA8, RA9, RA10, RA11, RA12, RA13, RA14	22k
Resistor Array	MNR04M0APJ102	Rohm	RA2, RA3, RA4, RA5, RA6	1k
Switch	MS-23AAP1	NKK	SW1	
Switch	B3FS-1000	Omron	SW2, SW4, SW6, SW7	

Switch	A6H-8102	Omron	SW3, SW5, SW8	
Test Pin	HK-2-G	MAC8	TP5, TP7, TP9, TP11, TP13, TP15, TP18, TP20, TP24, TP30, TP31, TP35, TP36	
IC	LTC6909CMS#PBF	LT	U1	
IC	74LVT08PW,112	NXP	U2	
IC	TPS386000RGPT	TI	U3, U12, U18	
IC	LTM4606EV#PBF	LT	U4, U5, U6, U8	
IC	LT3071EUFD#PBF	LT	U7, U9	
IC	TPS51200DRCR	TI	U10	
FPGA	XC7K160T-1FBG676C	Xilinx	U11	
IC	PC28F640P30TF65	Micron	U13	
IC	MT41J64M16JT-15E:G	Micron	U14	
Oscillator	KC7050T200.000L20E00	KYOCERA	U15, U16	200.000MHz
FPGA	XC6SLX45-2FG484C	Xilinx	U17	
IC	XCF32PVOG48C	Xilinx	U19	
Oscillator	KC5032C24.0000C20E00	KYOCERA	U20	24.000MHz
IC	FT2232HL-REEL	FTDI	U21	
Crystal Unit	NX3225DA-12.000MHz	NDK	U22	12.000MHz
IC	AT93C46D-TH-B	Atmel	U23	
Variable Resistor	ST32ETA103	Copal Electronics	VR1	10k

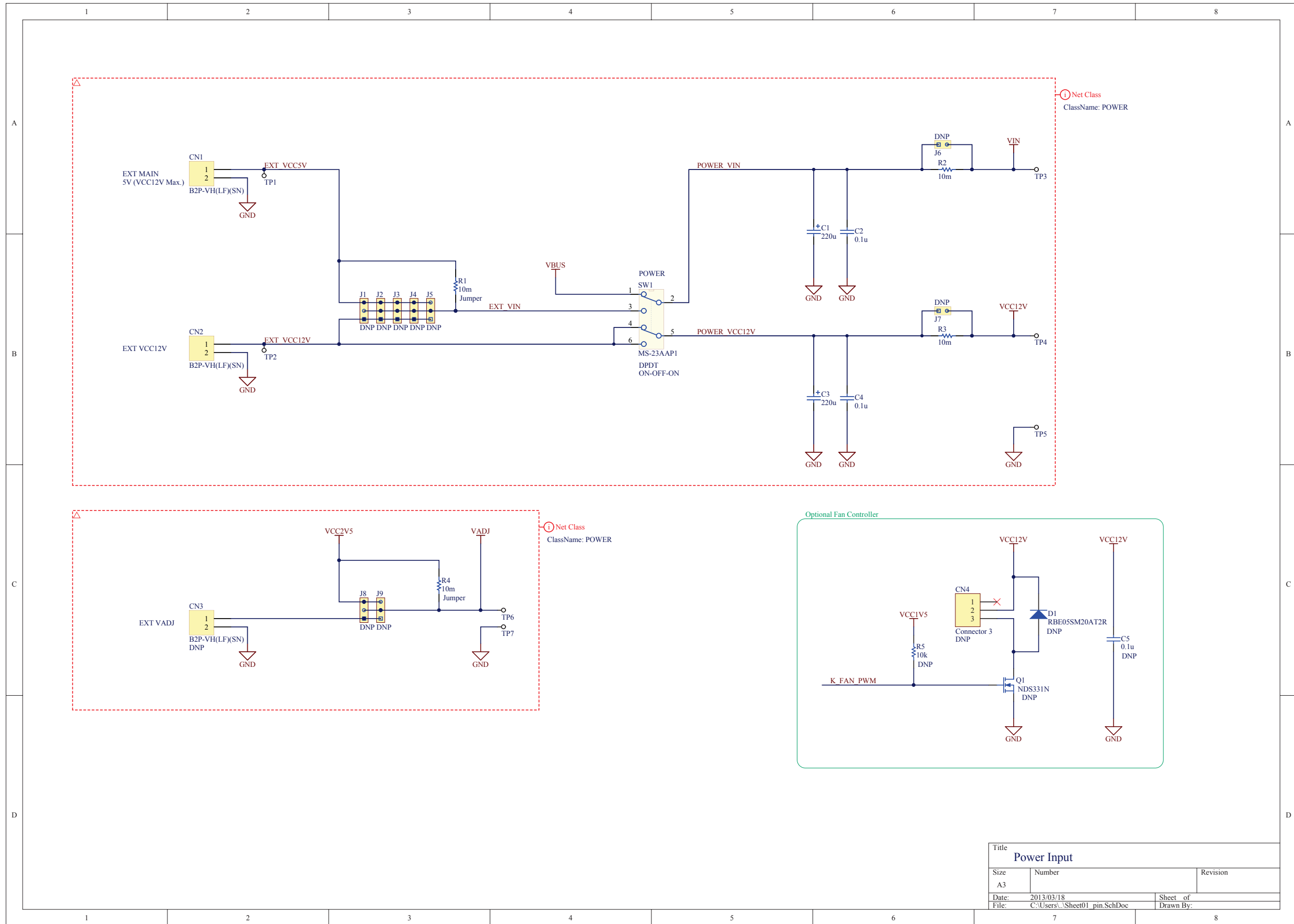

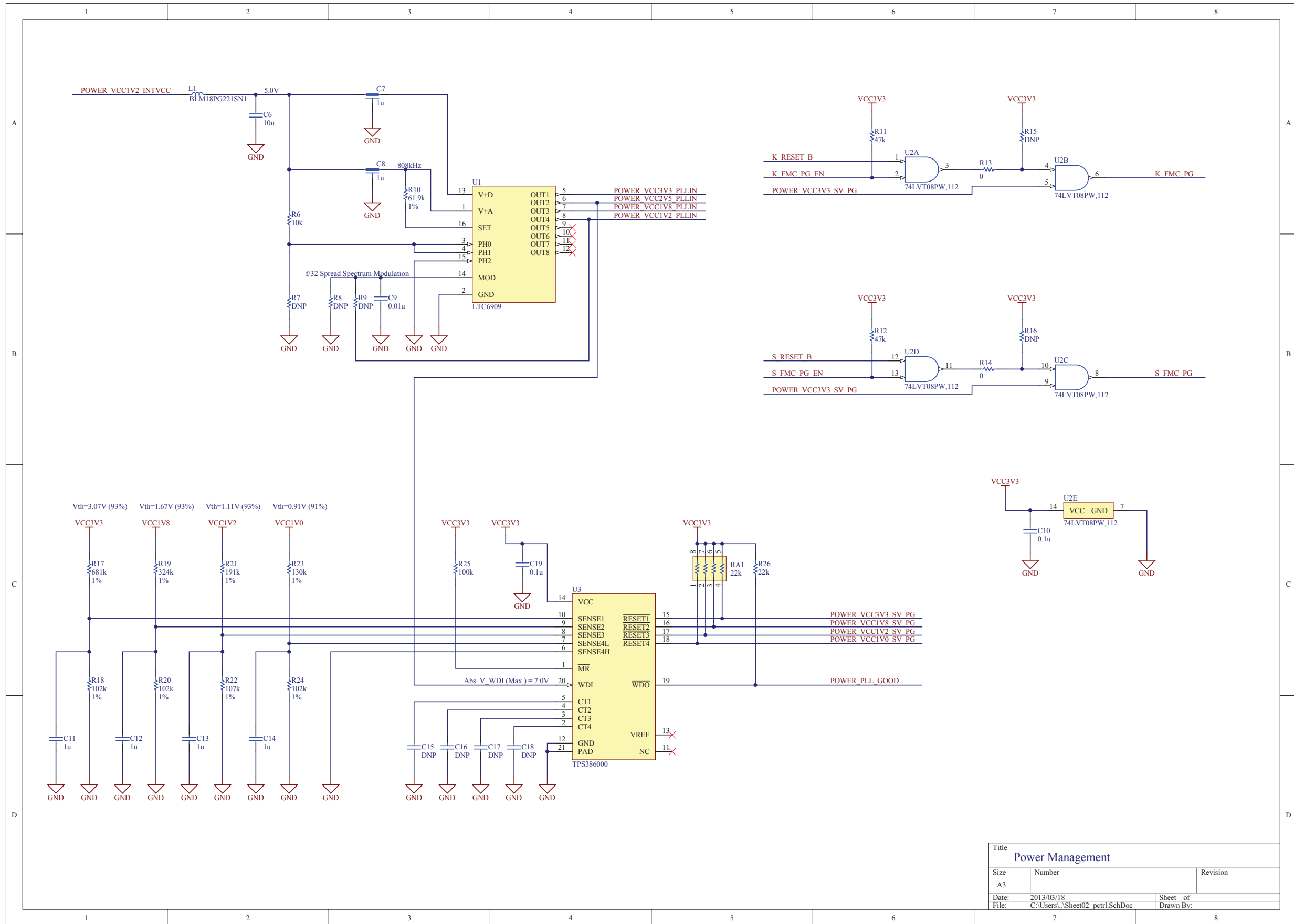

Title		
Power Management		
Size	Number	Revision
A3		
Date:	2013/03/18	Sheet of
File:	C:\Users\...\Sheet02_pctrl.SchDoc	Drawn By:

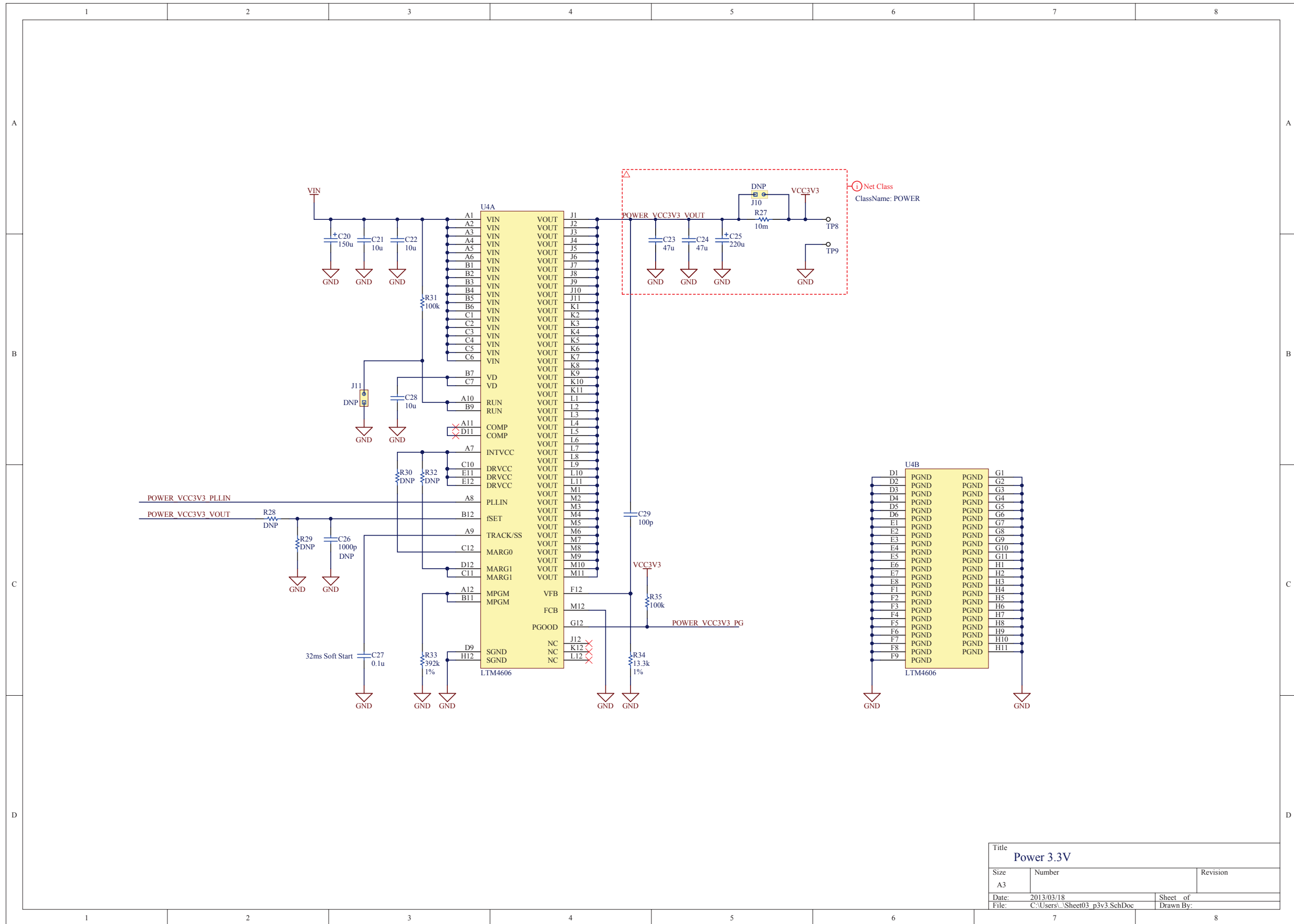

Title		
Power 3.3V		
Size	Number	Revision
A3		
Date:	2013/03/18	Sheet of
File:	C:\Users\...\Sheet03_p3v3.SchDoc	Drawn By:

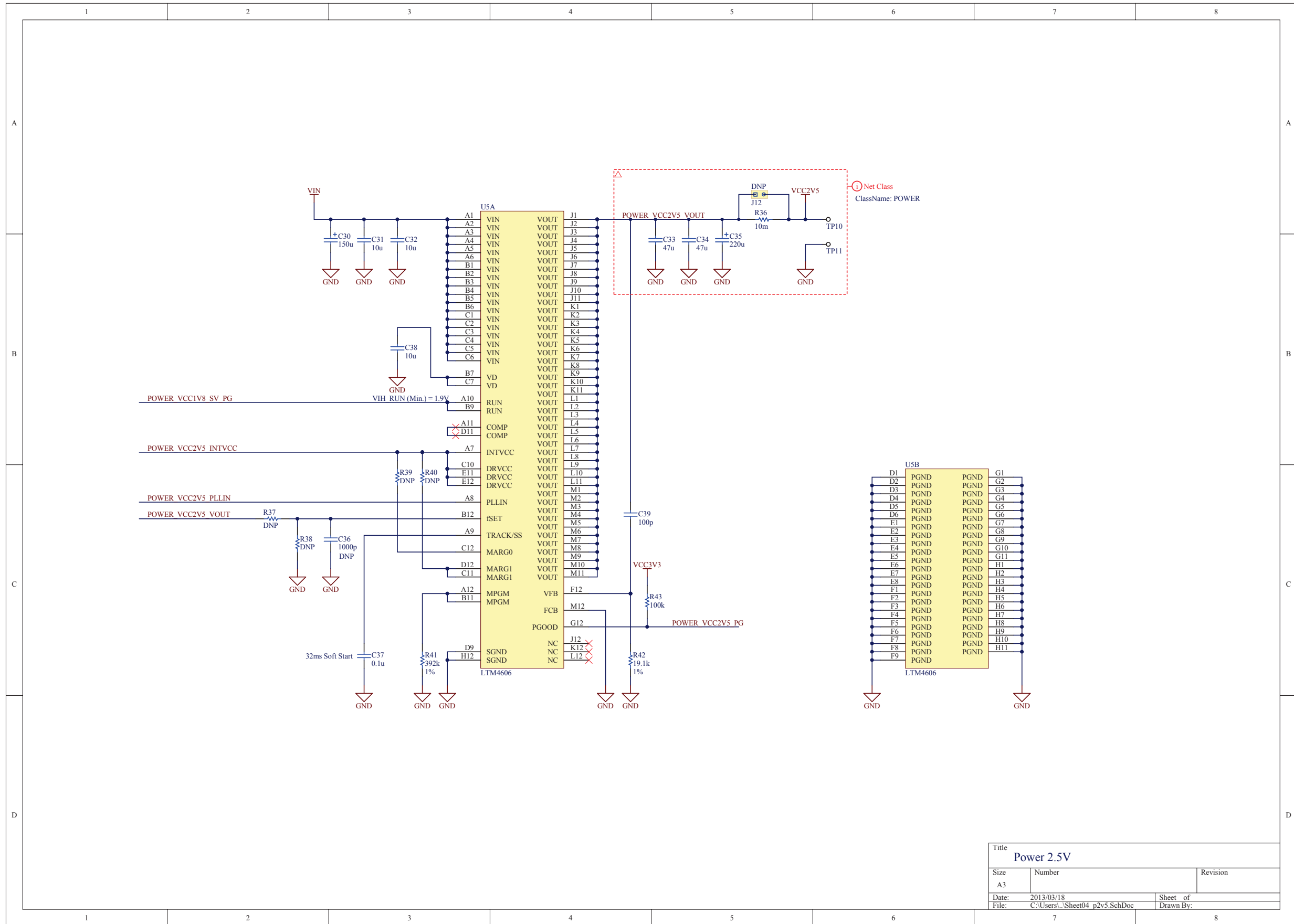

Title		
Power 2.5V		
Size	Number	Revision
A3		
Date:	2013/03/18	Sheet of
File:	C:\Users\...\Sheet04_p2v5.SchDoc	Drawn By:

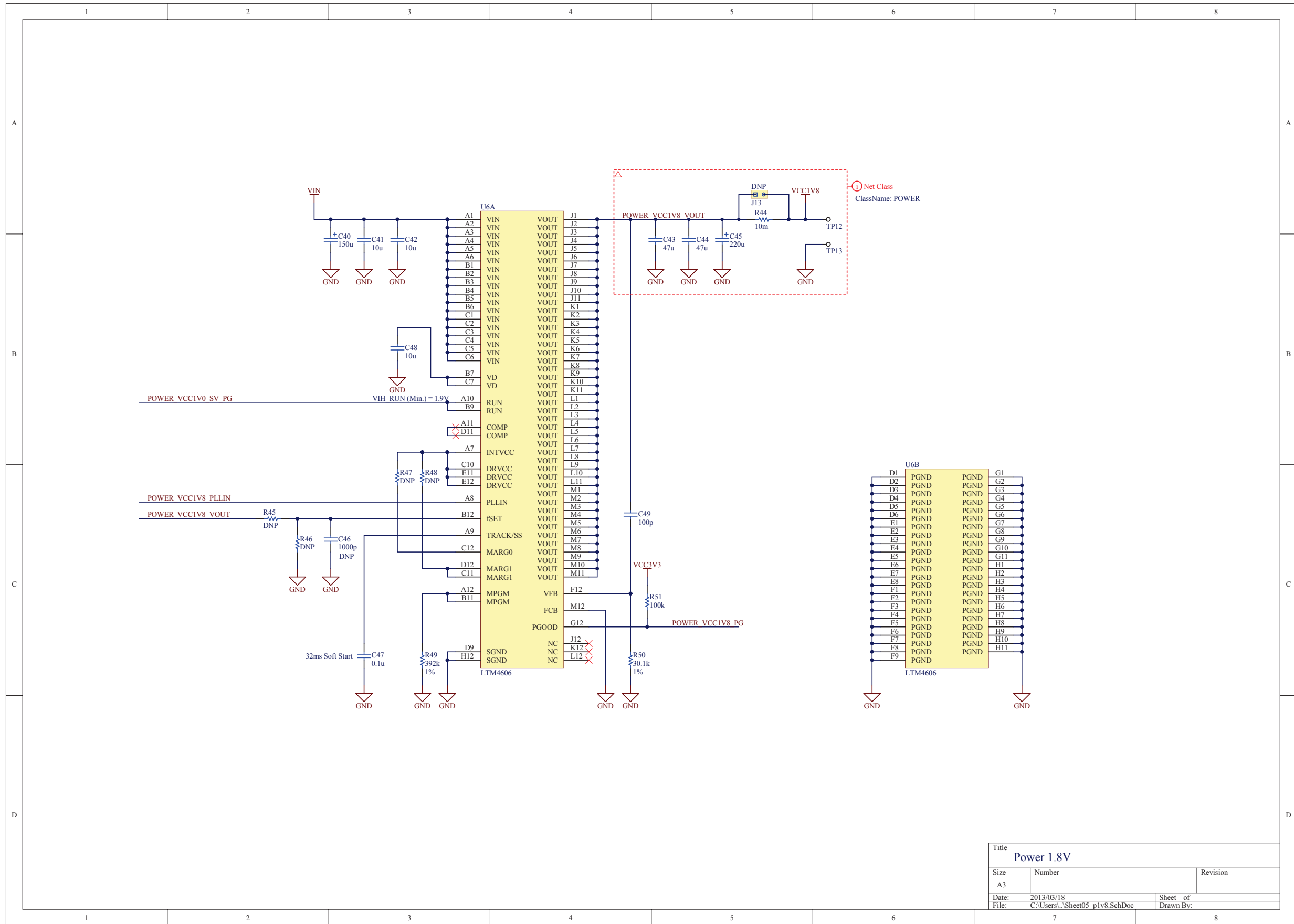

Title		
Power 1.8V		
Size	Number	Revision
A3		
Date:	2013/03/18	Sheet of
File:	C:\Users\...\Sheet05_p1v8.SchDoc	Drawn By:

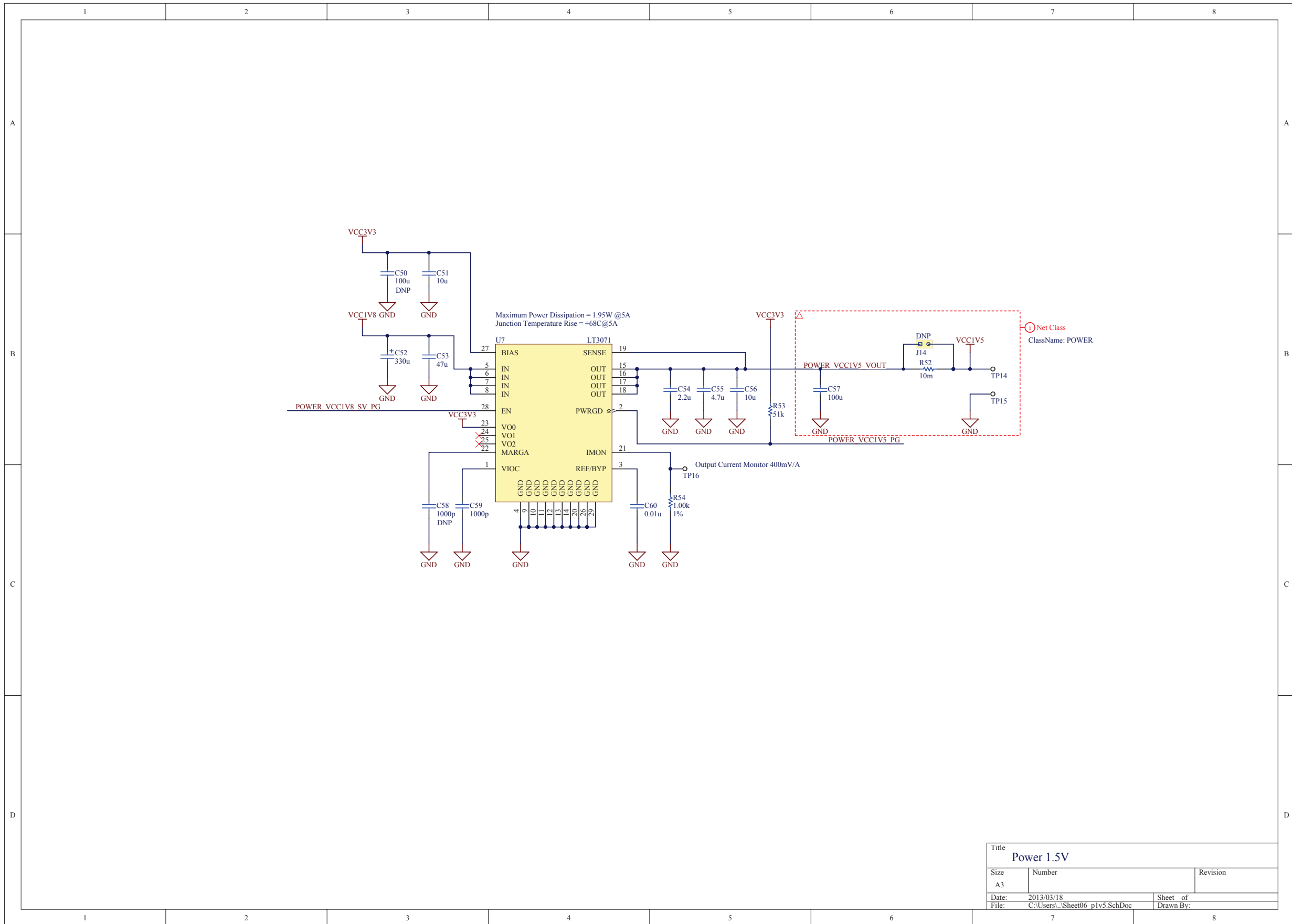

Title Power 1.5V		
Size A3	Number	Revision
Date: 2013/03/18	File: C:\Users\...\Sheet06_p1v5.SchDoc	Sheet of Drawn By:

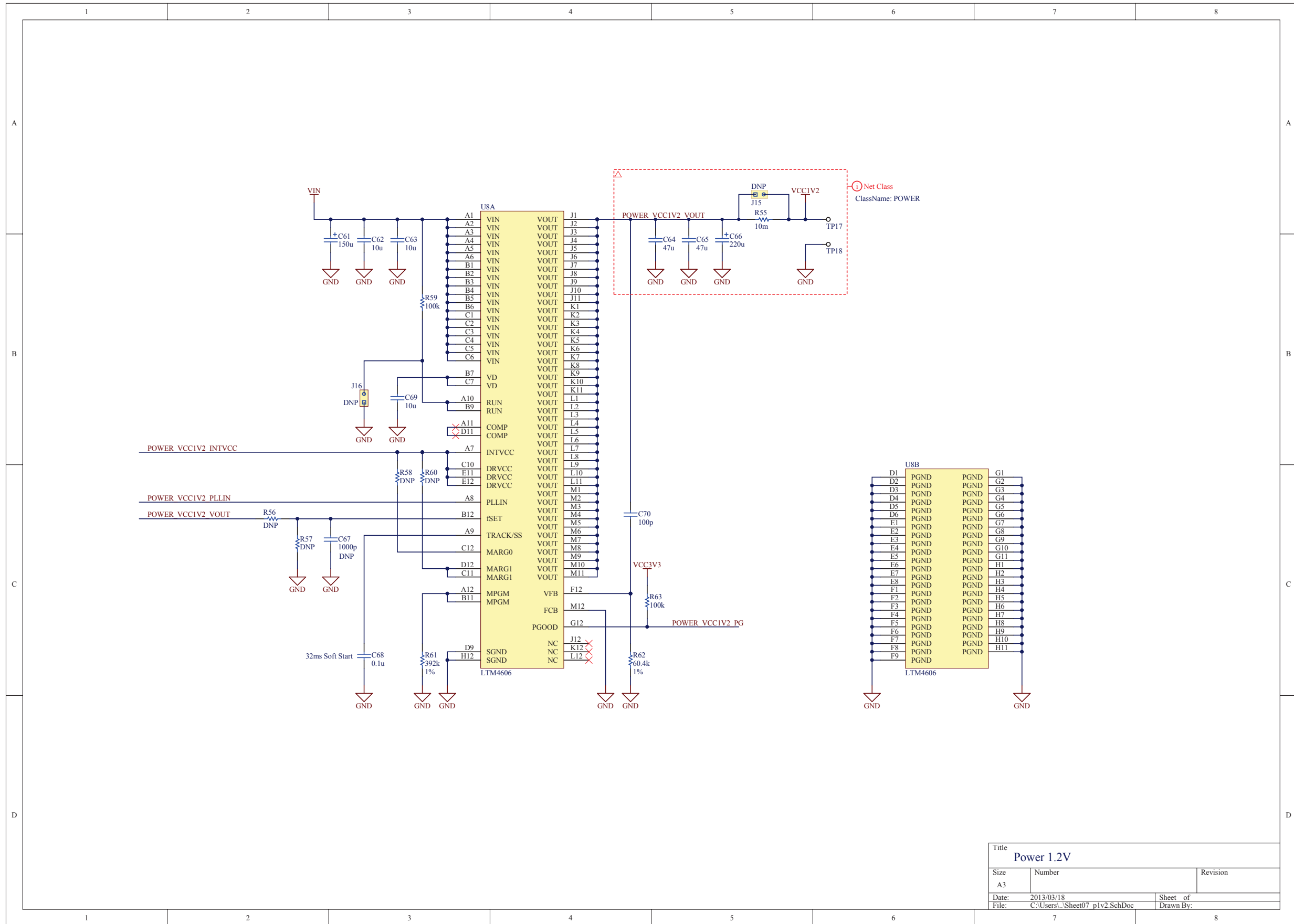

Title		
Power 1.2V		
Size	Number	Revision
A3		
Date:	2013/03/18	Sheet of
File:	C:\Users\...\Sheet07_p1v2.SchDoc	Drawn By:

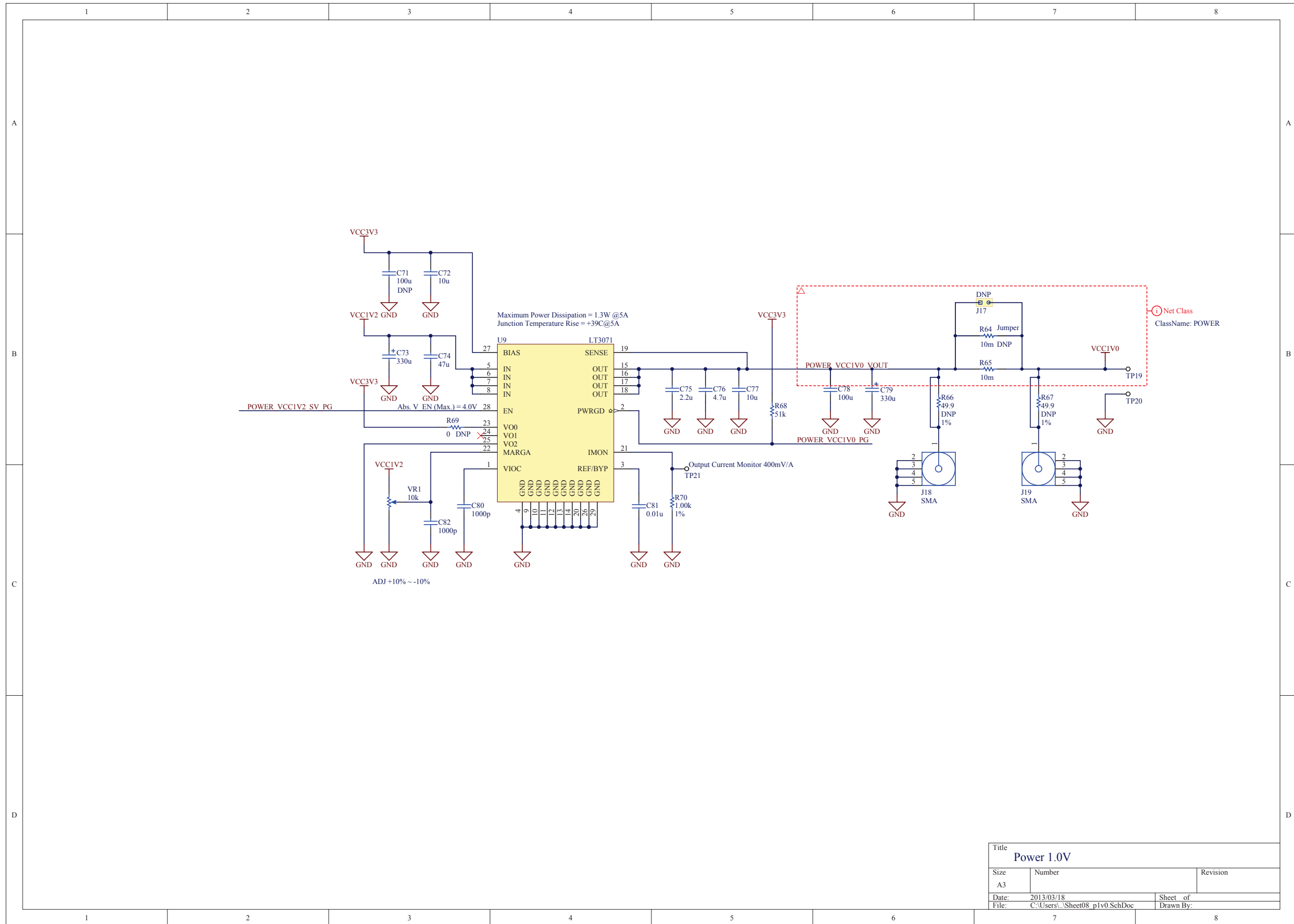

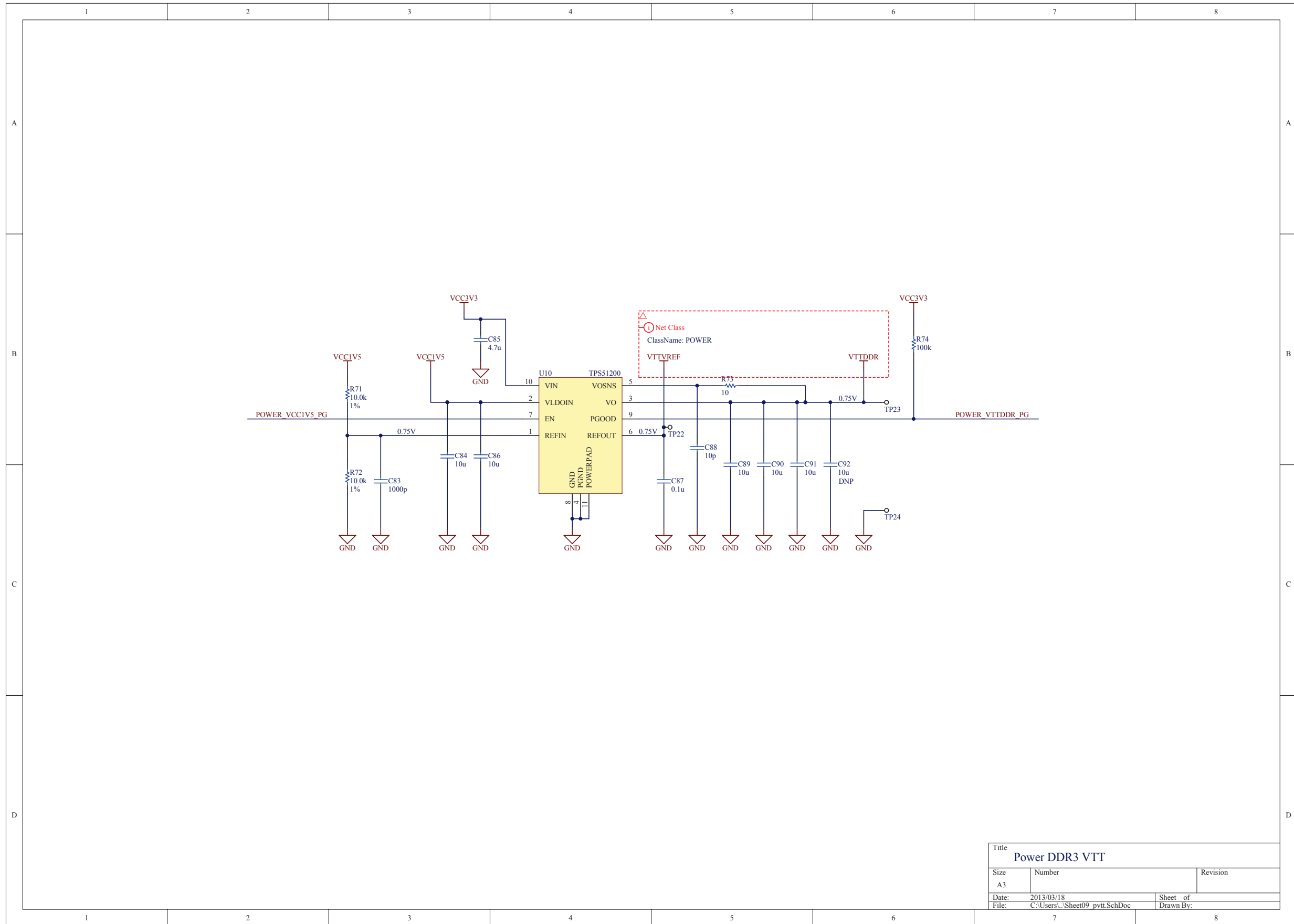

Title Power DDR3 VTT		
Size A3	Number	Revision
Date: 2013/03/18	Sheet of	
File: C:\Users\...\Sheet09_pvt.SchDoc	Drawn By:	

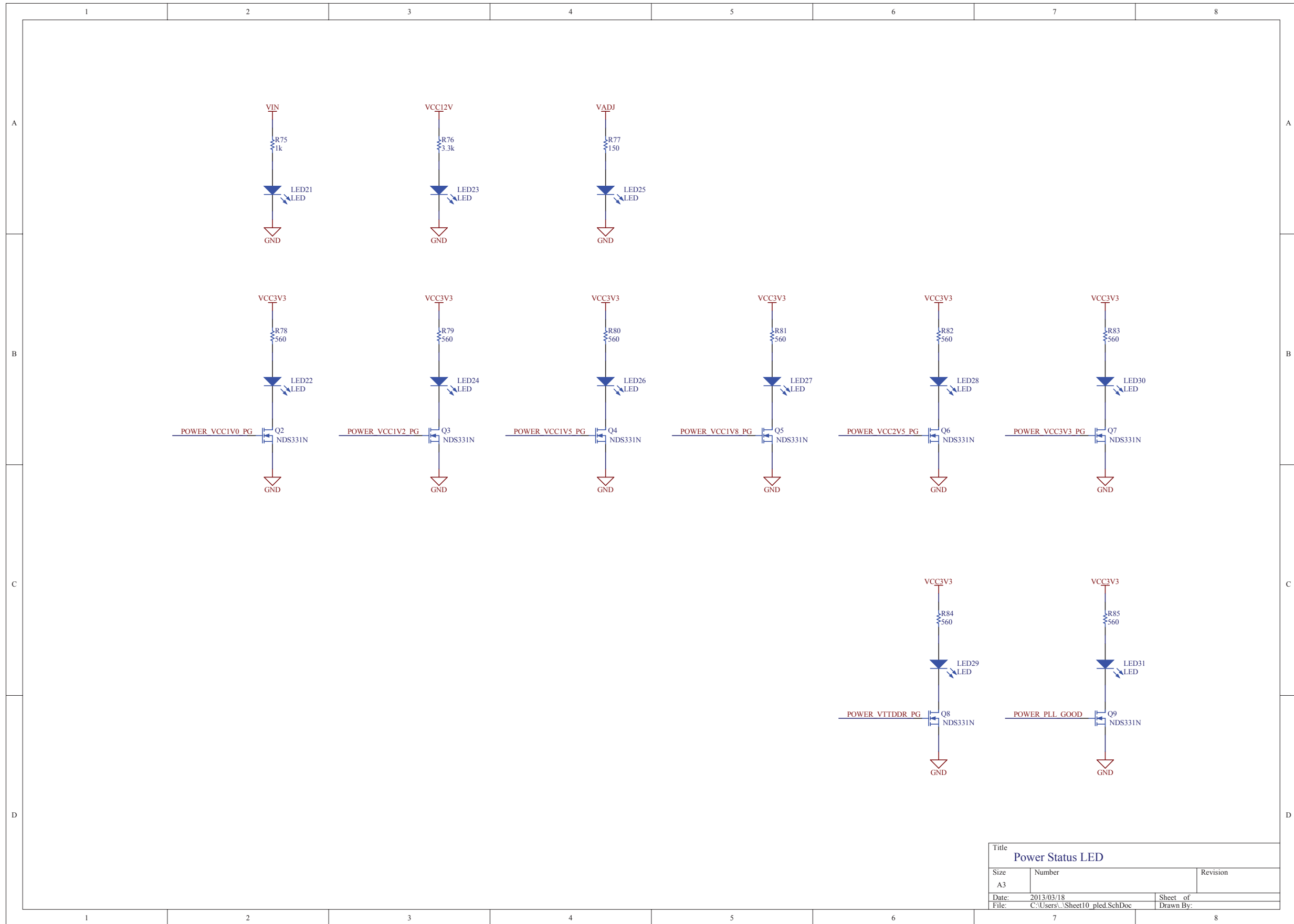

Title Power Status LED		
Size A3	Number	Revision
Date: 2013/03/18	Sheet of	
File: C:\Users\...\Sheet10_pled.SchDoc	Drawn By:	

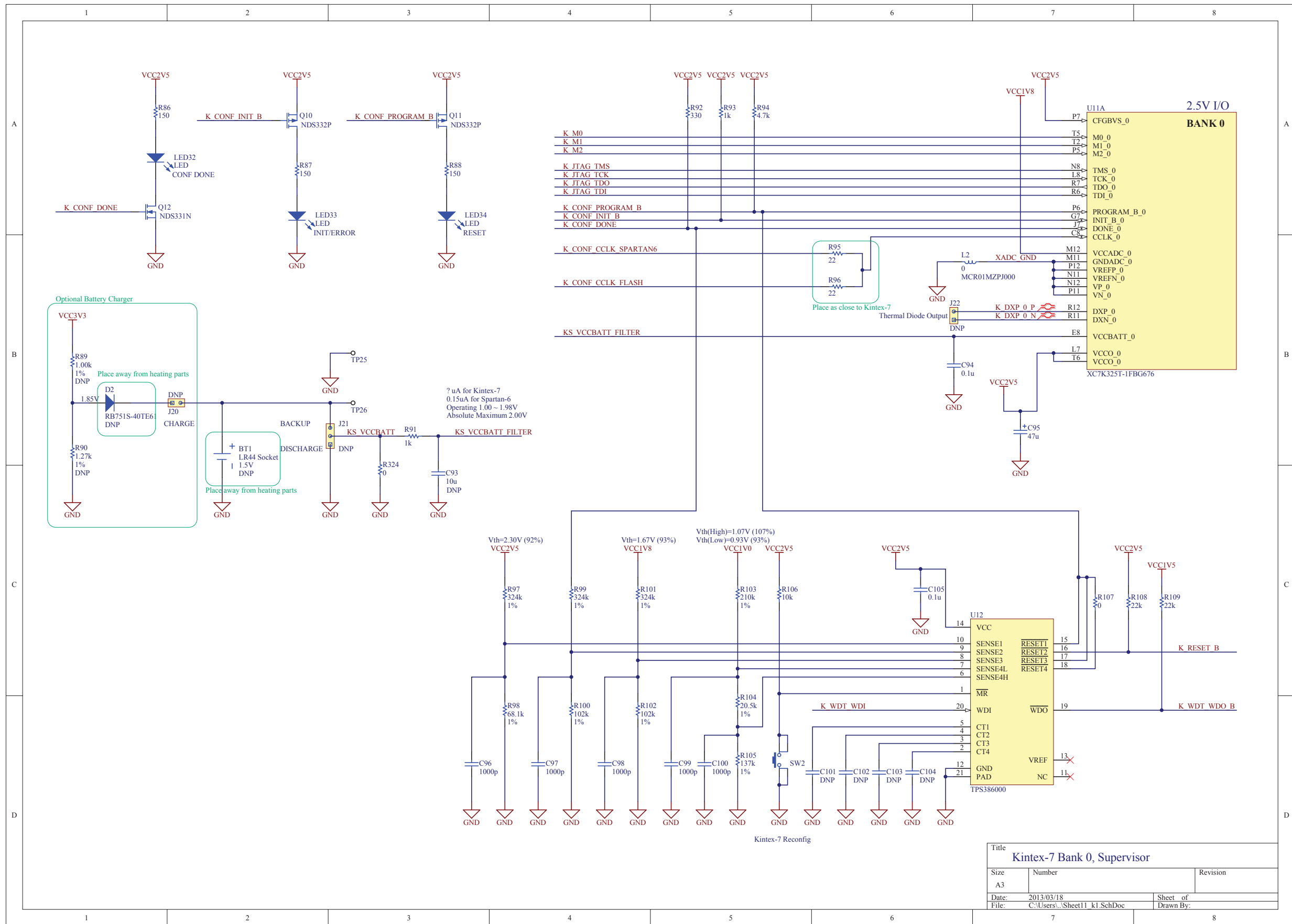

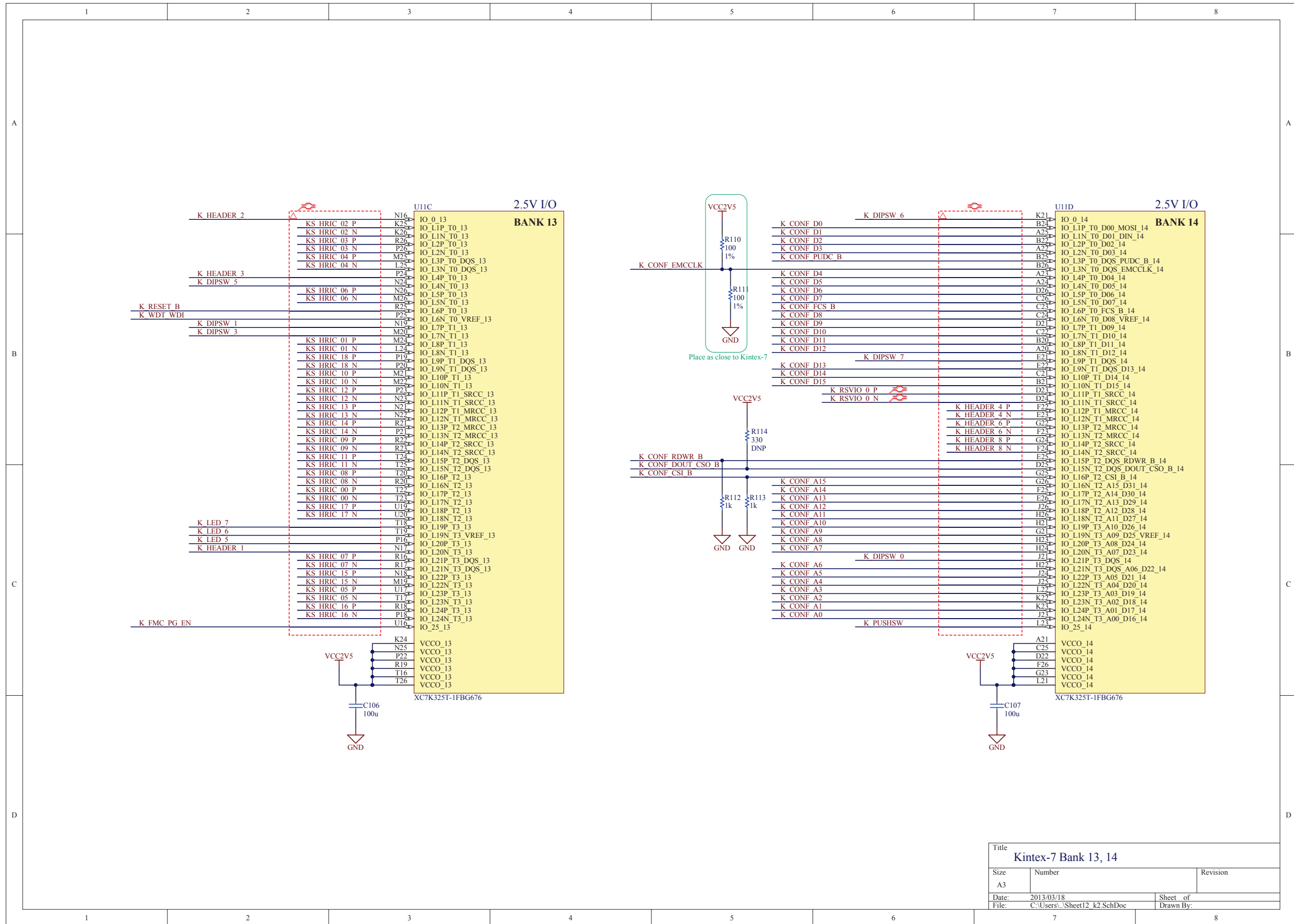

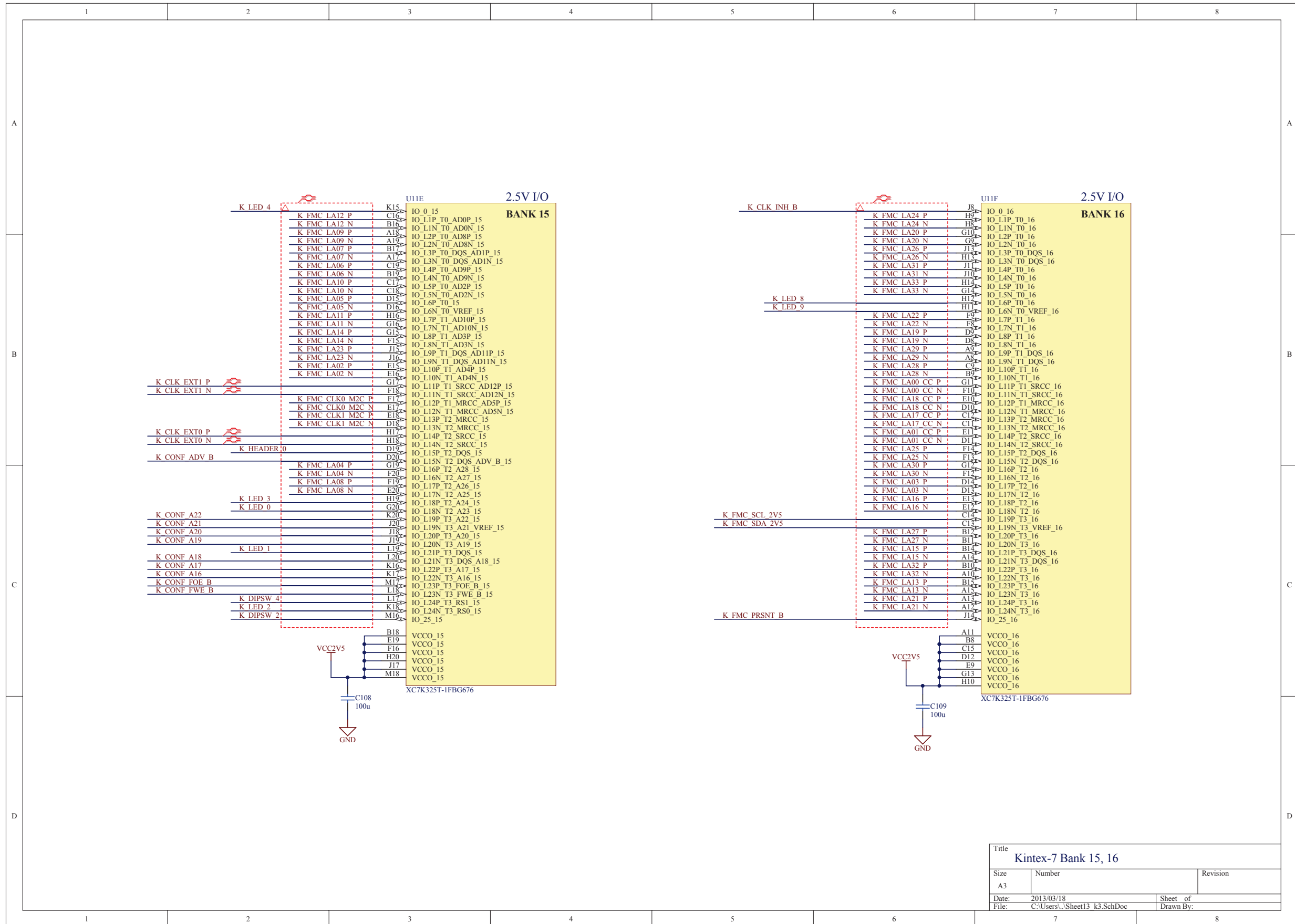

Title		
Kintex-7 Bank 15, 16		
Size	Number	Revision
A3		
Date:	2013/03/18	Sheet of
File:	C:\Users\...Sheet13_k3.SchDoc	Drawn By:

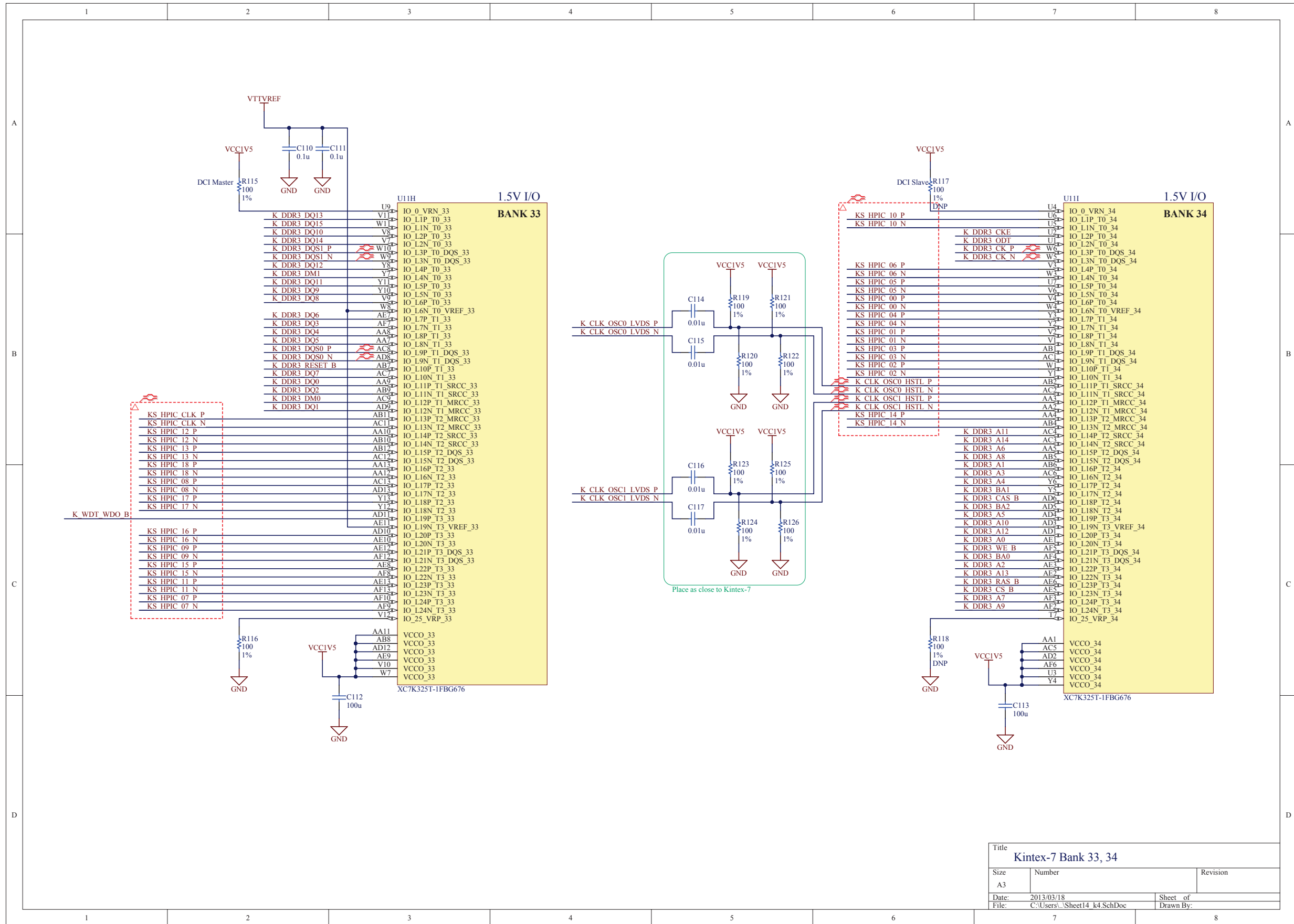

Title		
Kintex-7 Bank 33, 34		
Size	Number	Revision
A3		
Date:	2013/03/18	Sheet of
File:	C:\Users\...Sheet14.k4.SchDoc	Drawn By:

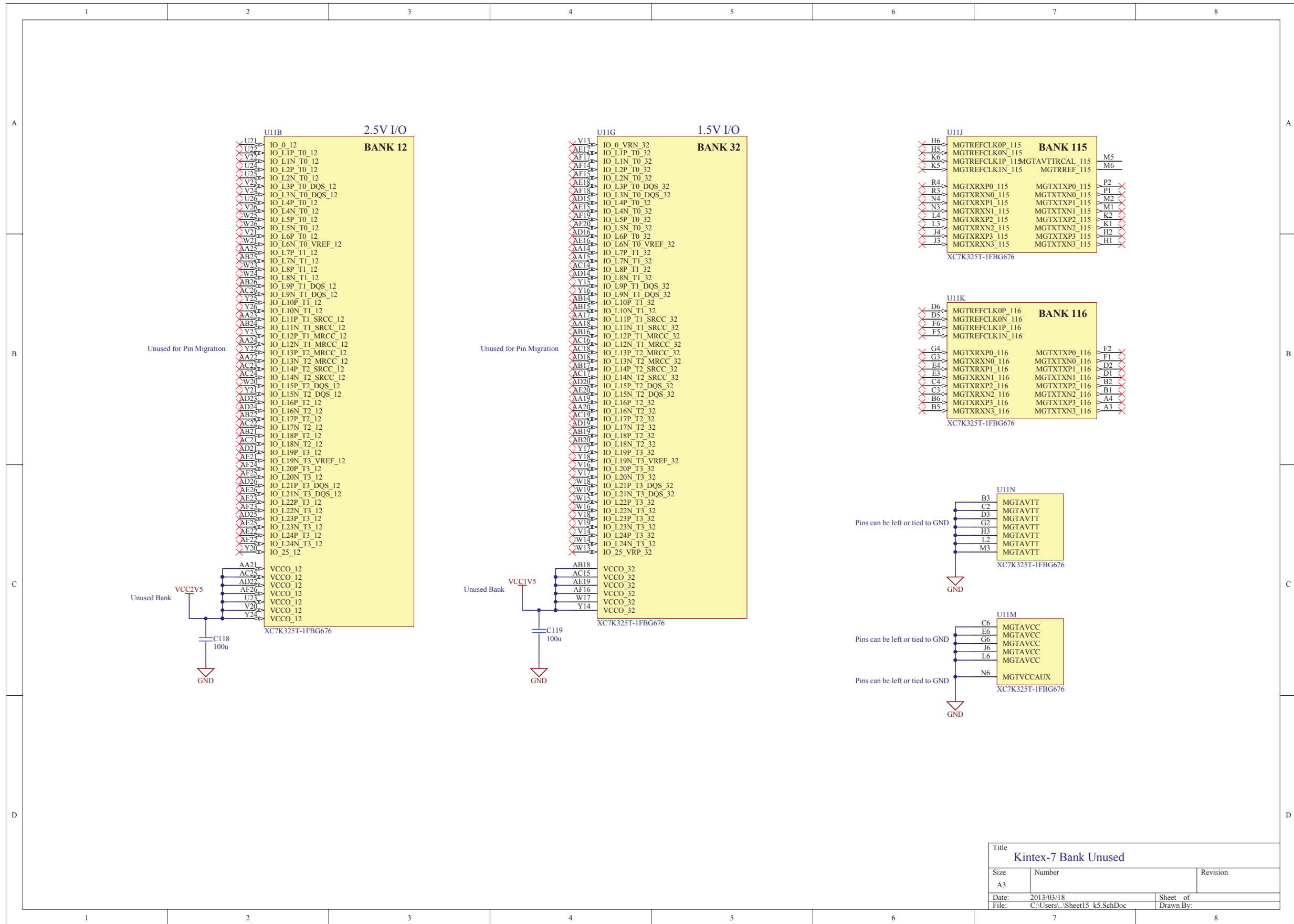

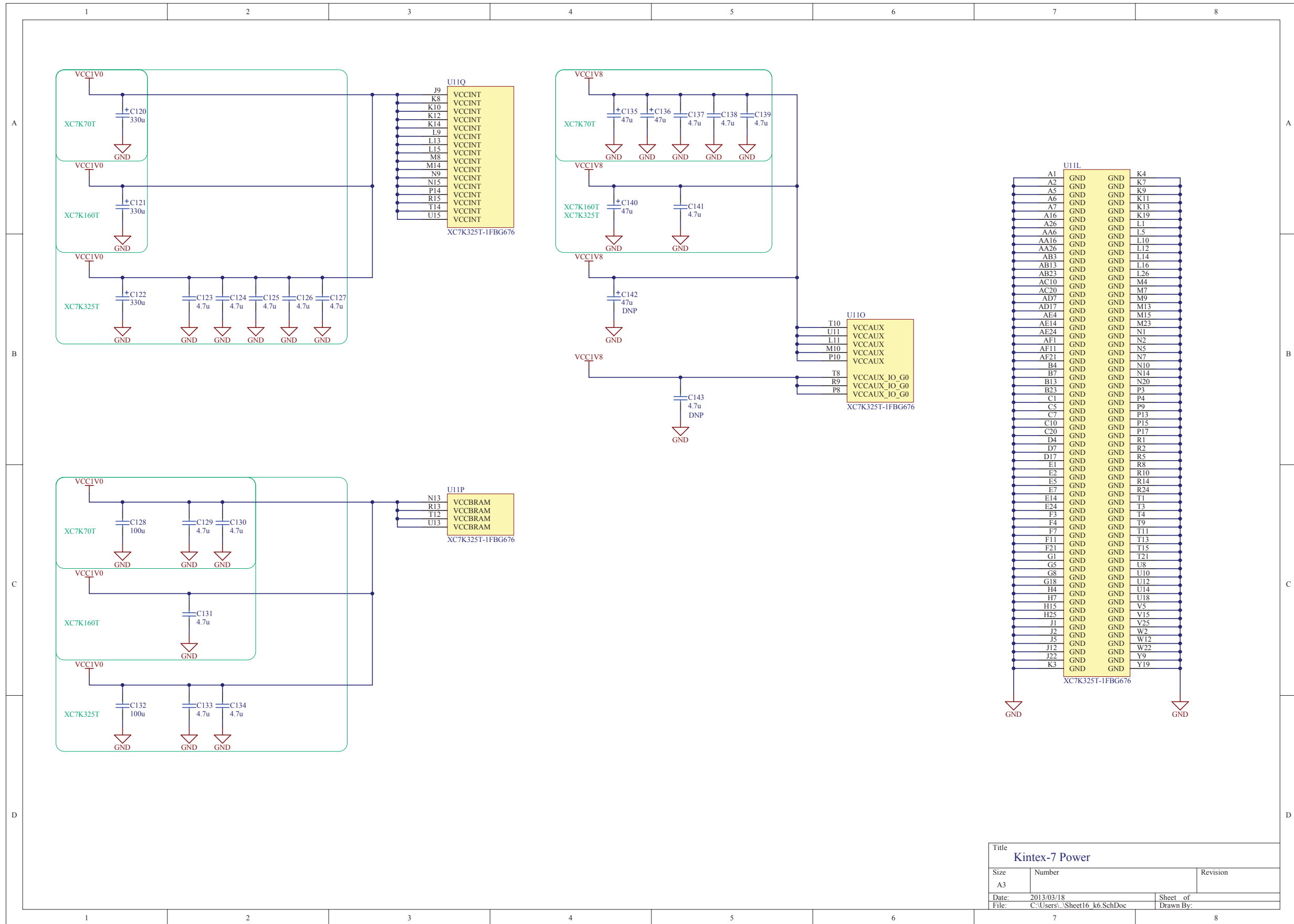

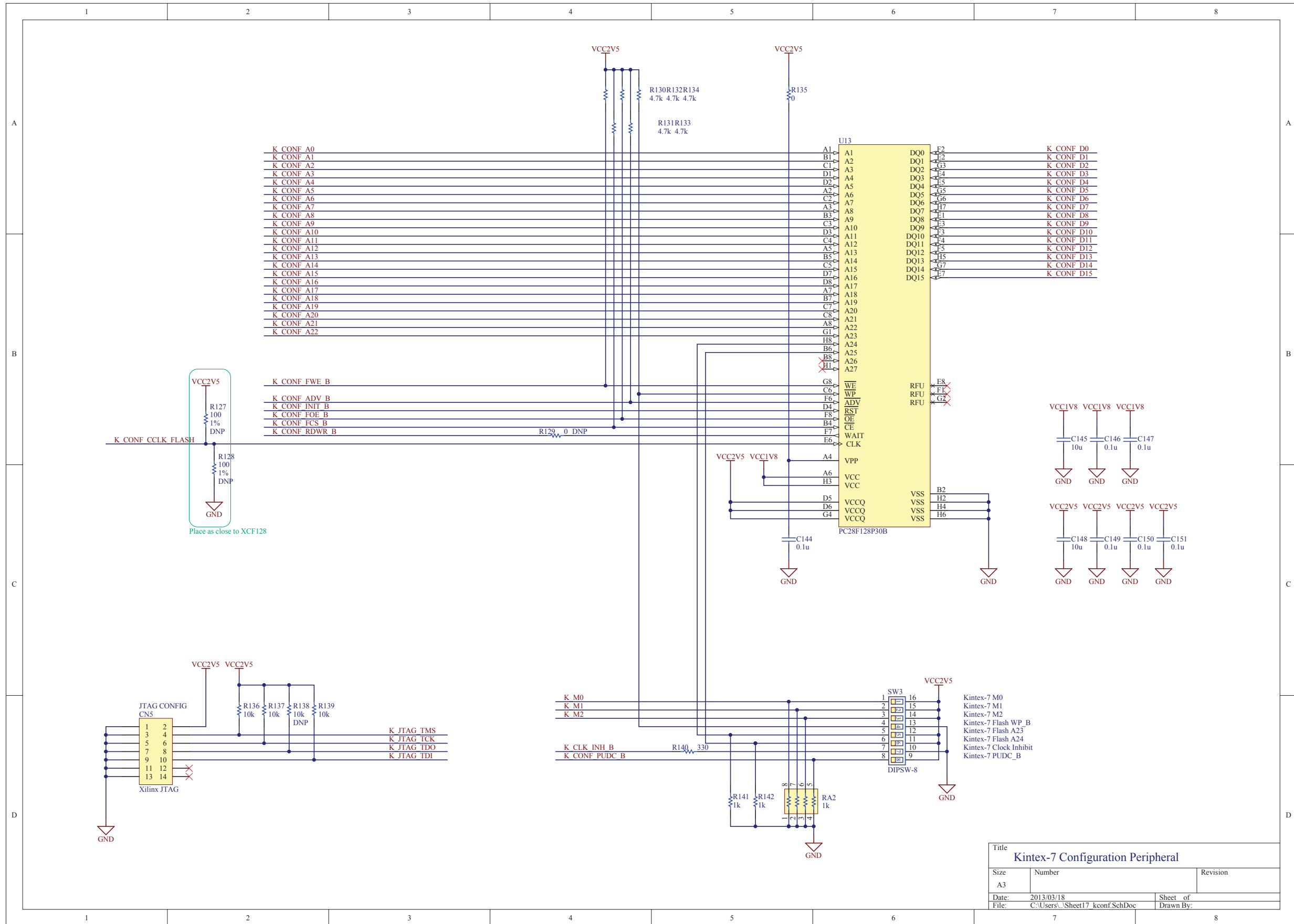

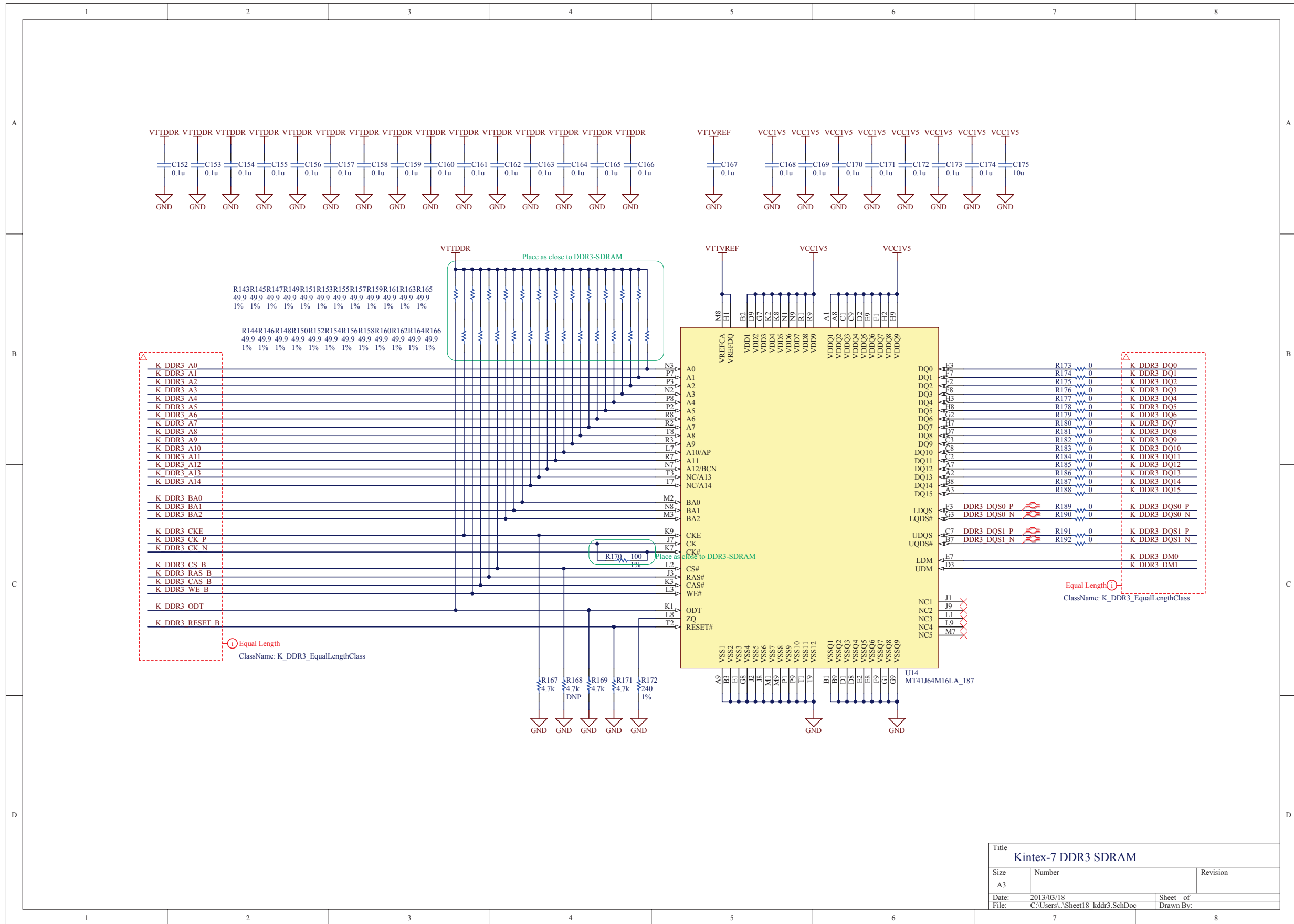

Title		
Kintex-7 DDR3 SDRAM		
Size	Number	Revision
A3		
Date:	2013/03/18	Sheet of
File:	C:\Users\...Sheet18_kddr3.SchDoc	Drawn By:

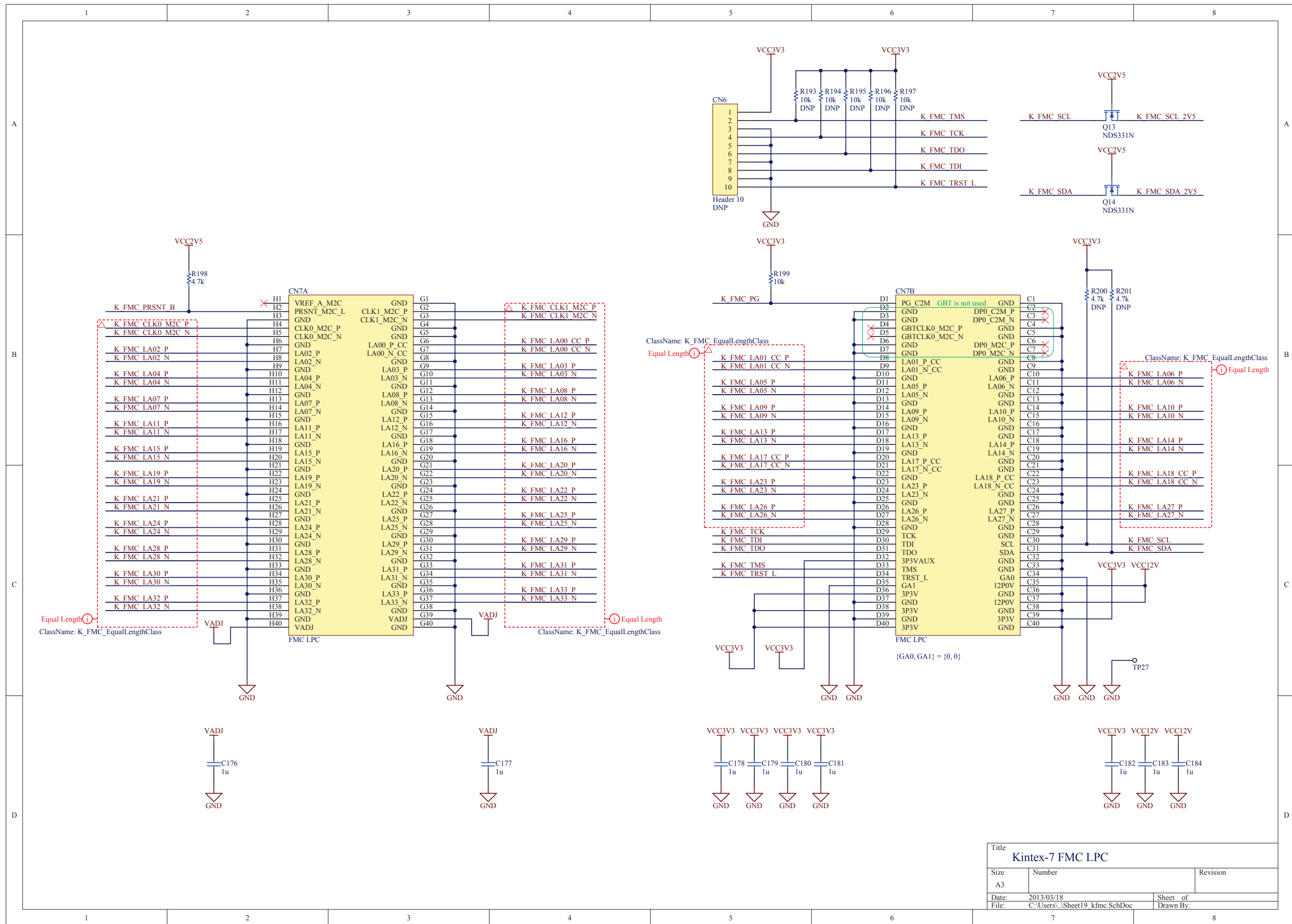

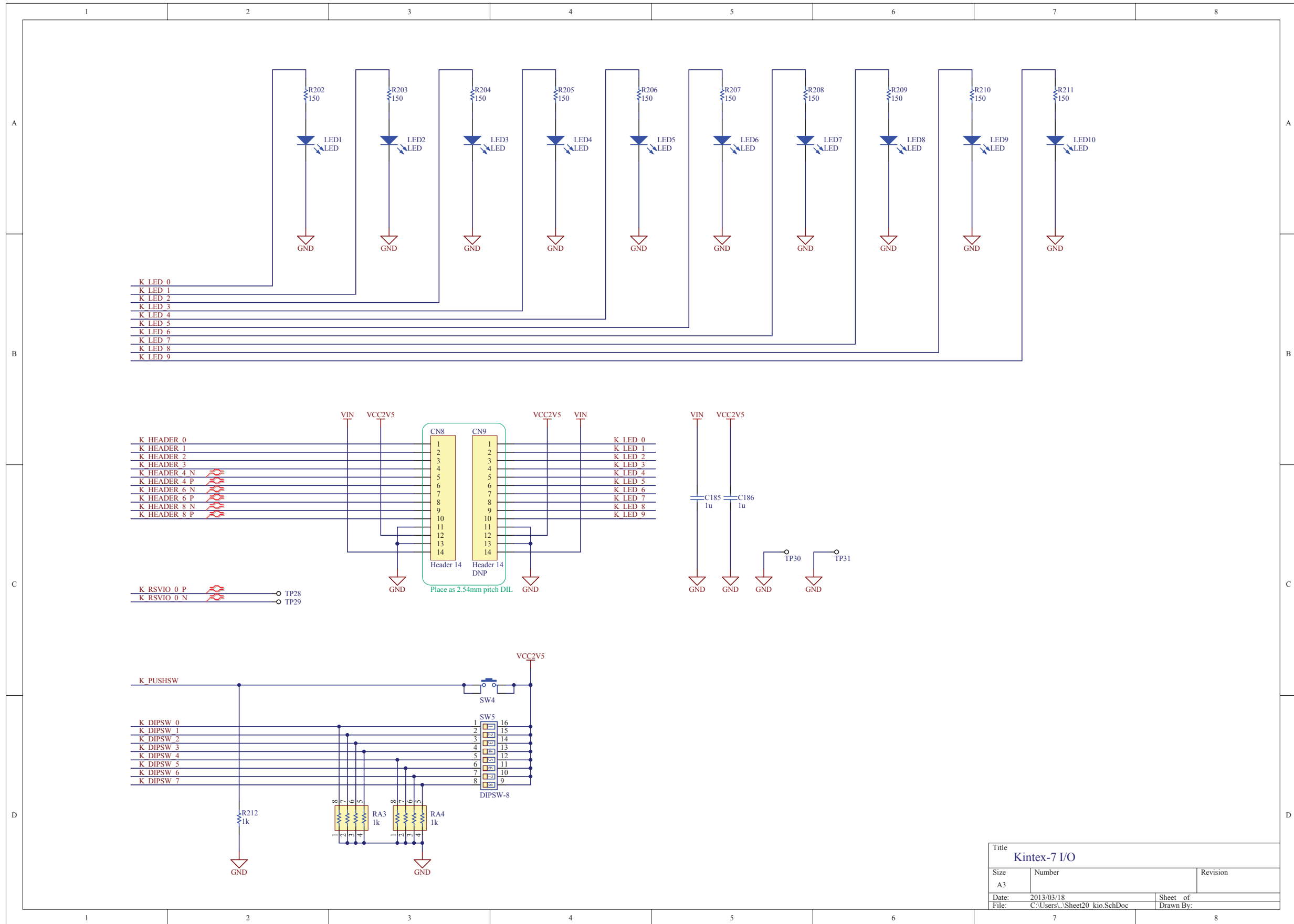

Title Kintex-7 I/O		
Size A3	Number	Revision
Date: 2013/03/18	Sheet of	
File: C:\Users\...\Sheet20_kio.SchDoc	Drawn By:	

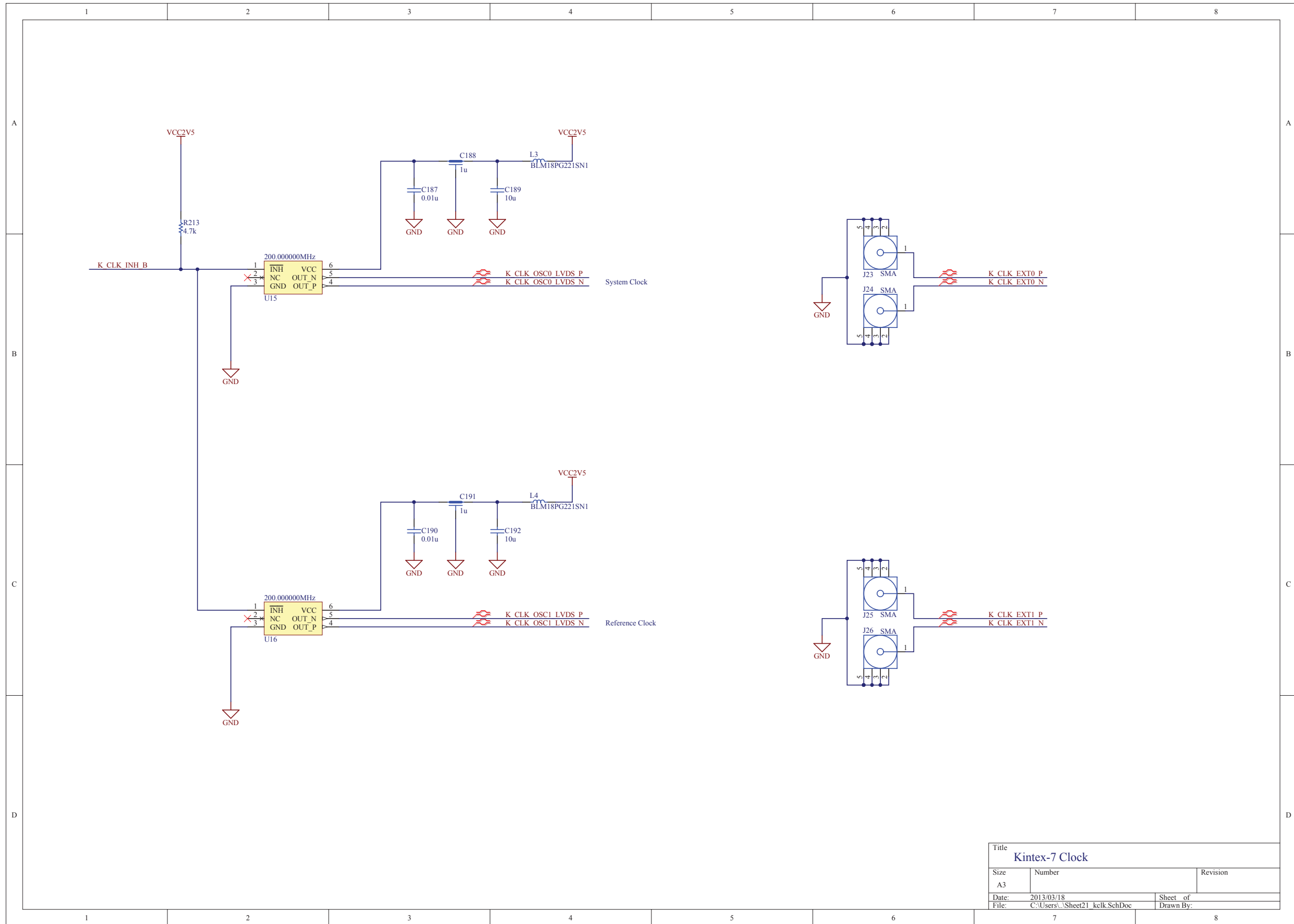

Title Kintex-7 Clock		
Size A3	Number	Revision
Date: 2013/03/18	Sheet of	
File: C:\Users\...\Sheet21_kclk.SchDoc	Drawn By:	

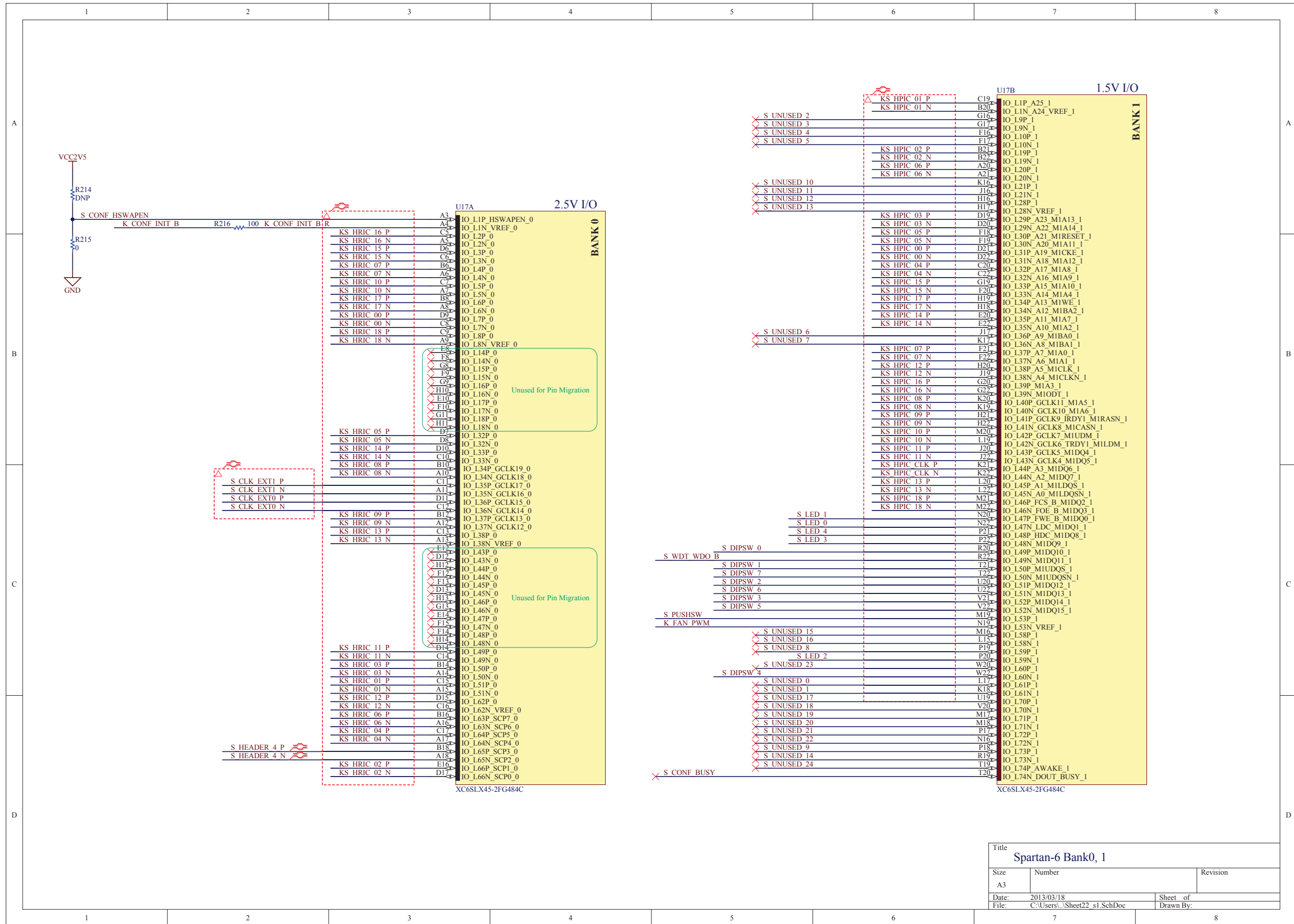

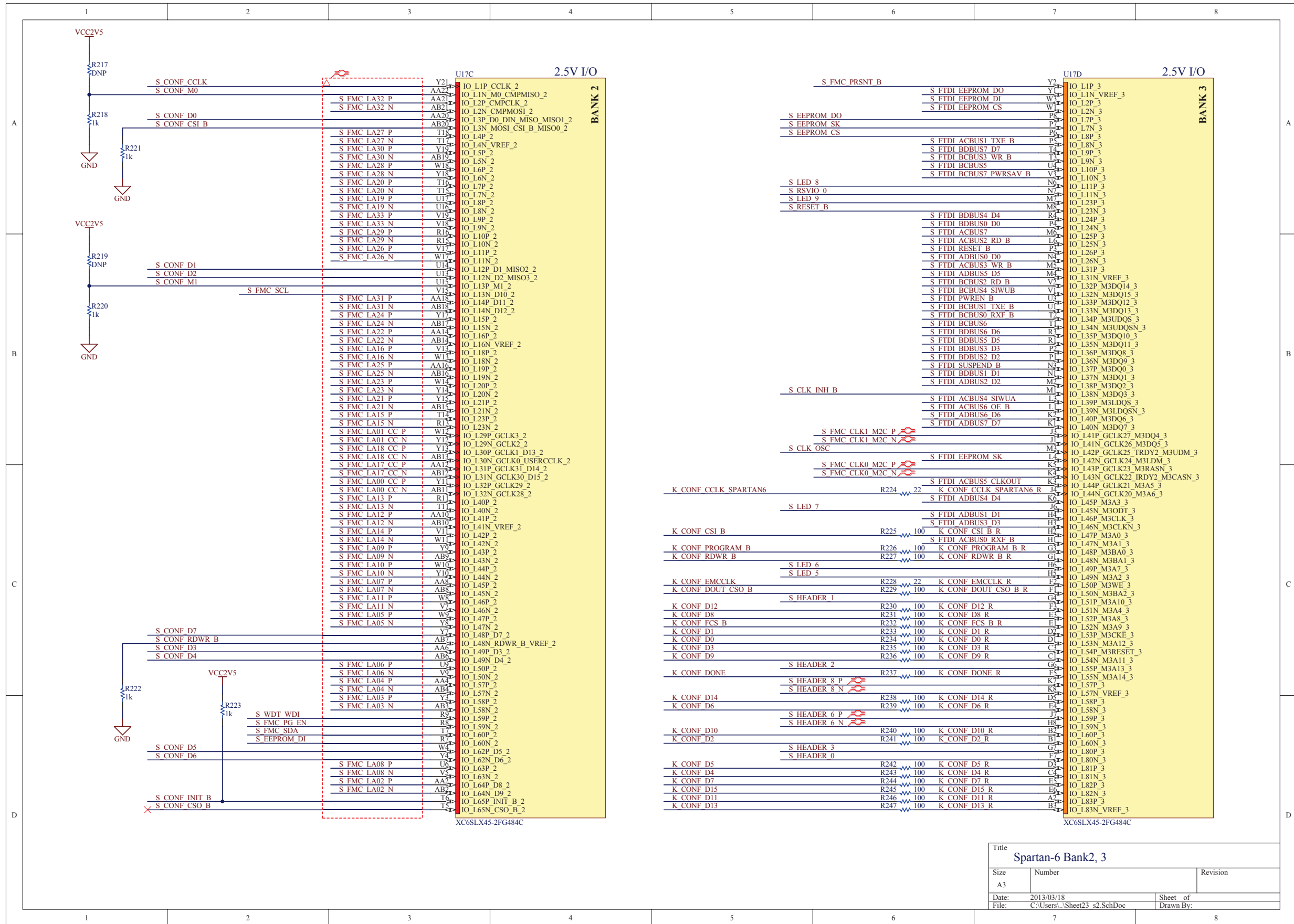

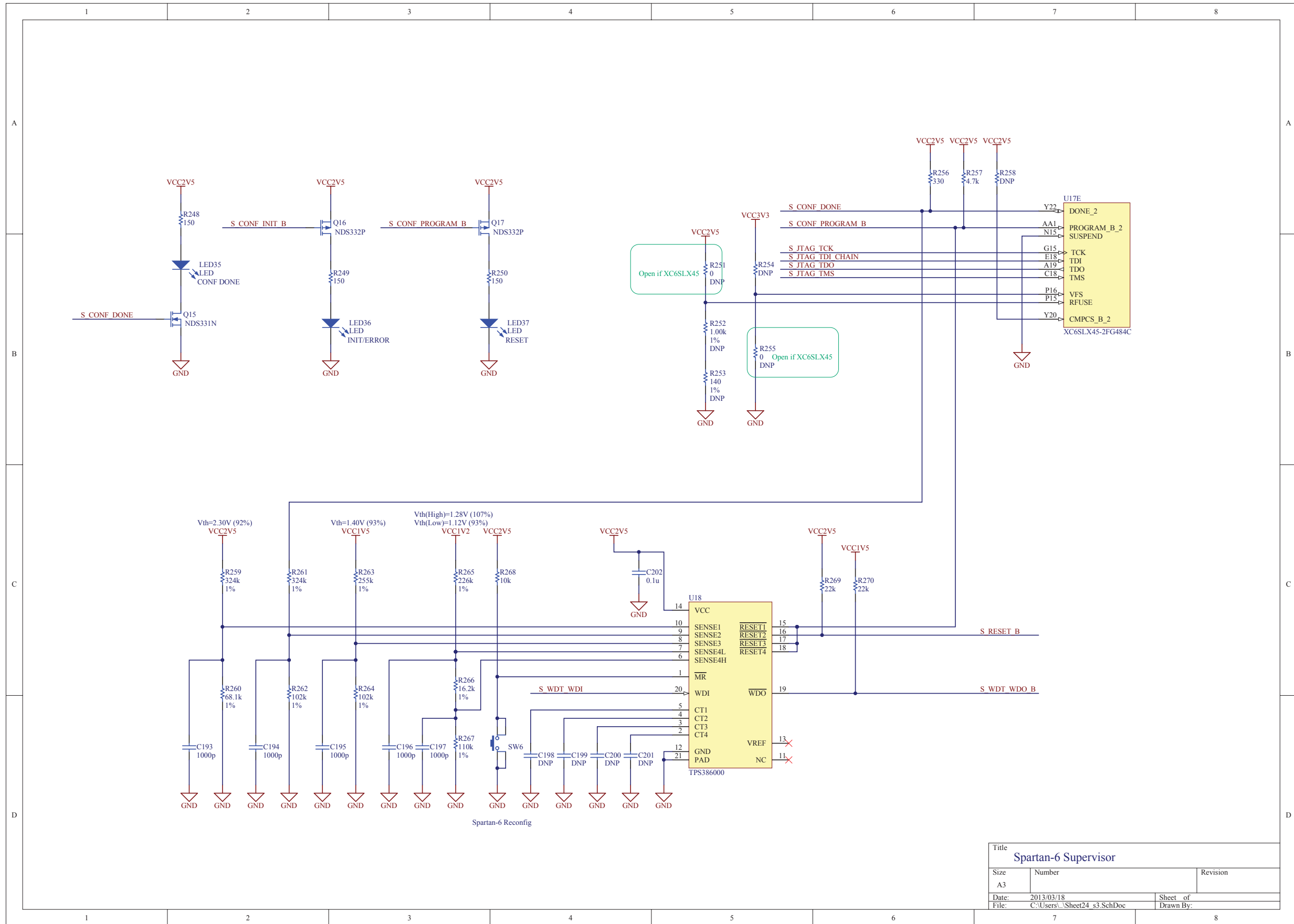

Title		
Spartan-6 Supervisor		
Size	Number	Revision
A3		
Date:	2013/03/18	Sheet of
File:	C:\Users\... \Sheet24_s3.SchDoc	Drawn By:

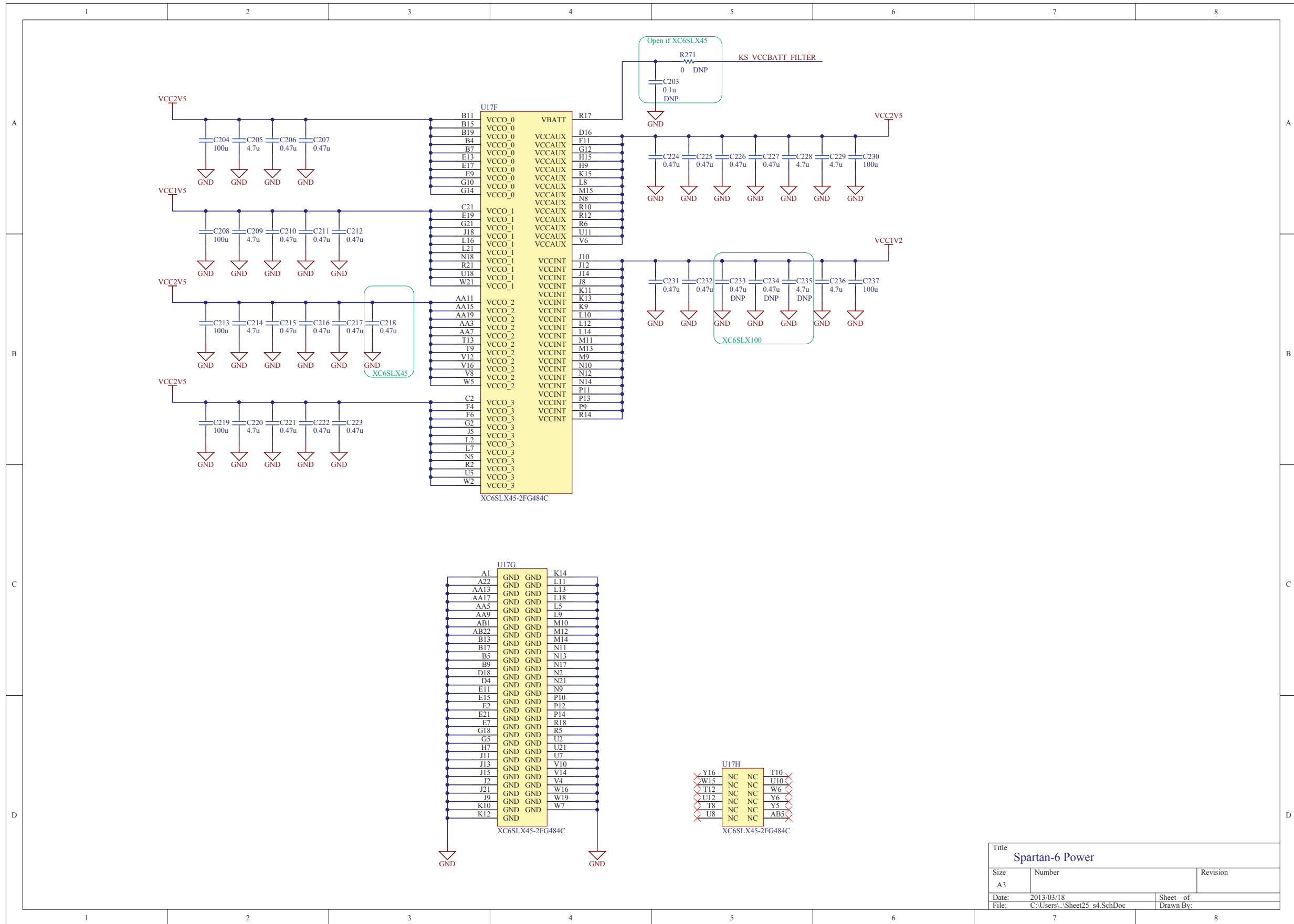

Title Spartan-6 Power		
Size A3	Number	Revision
Date: 2013/03/18	Sheet of	
File: C:\Users\...Sheet25_s4.SchDoc	Drawn By:	

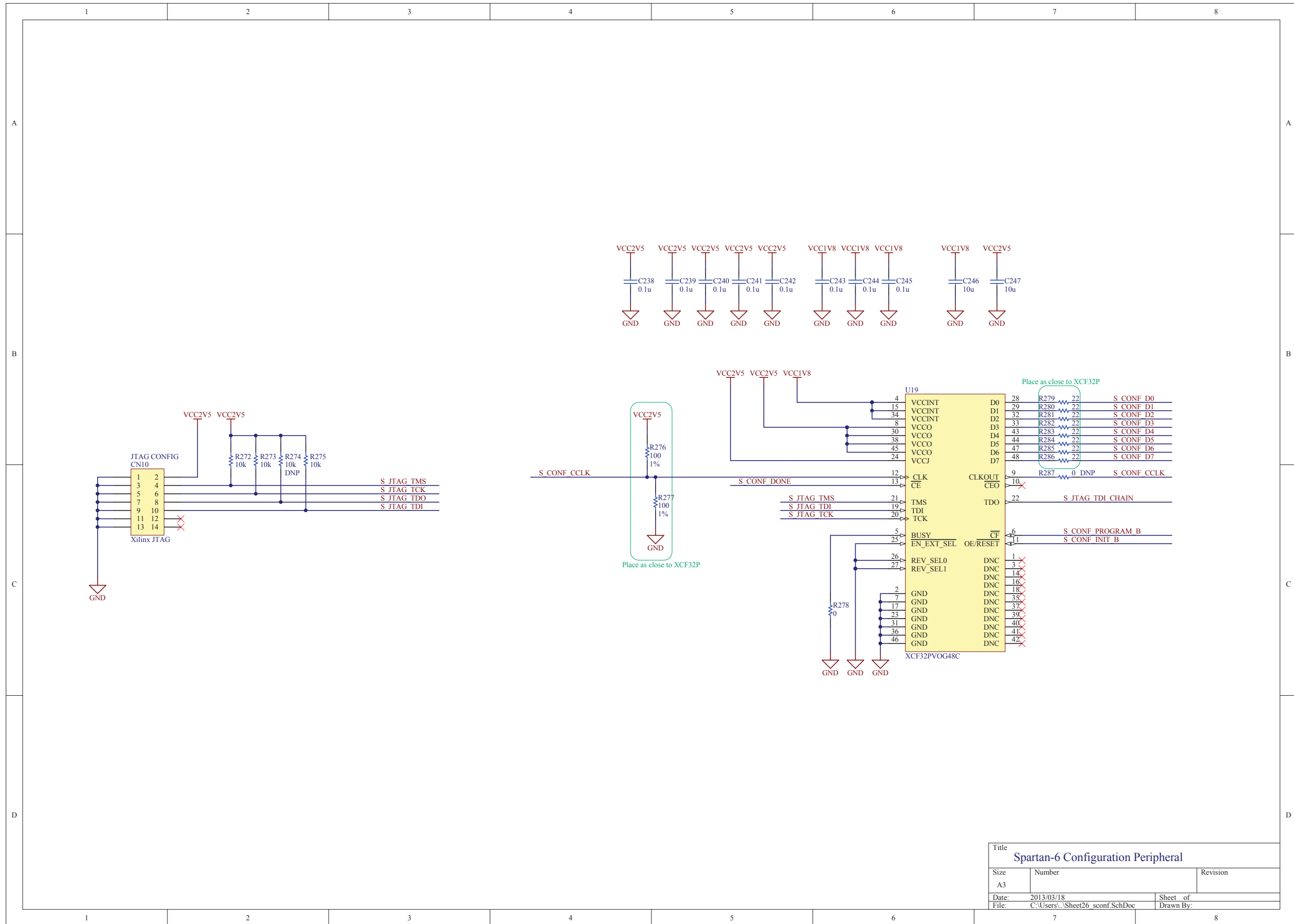

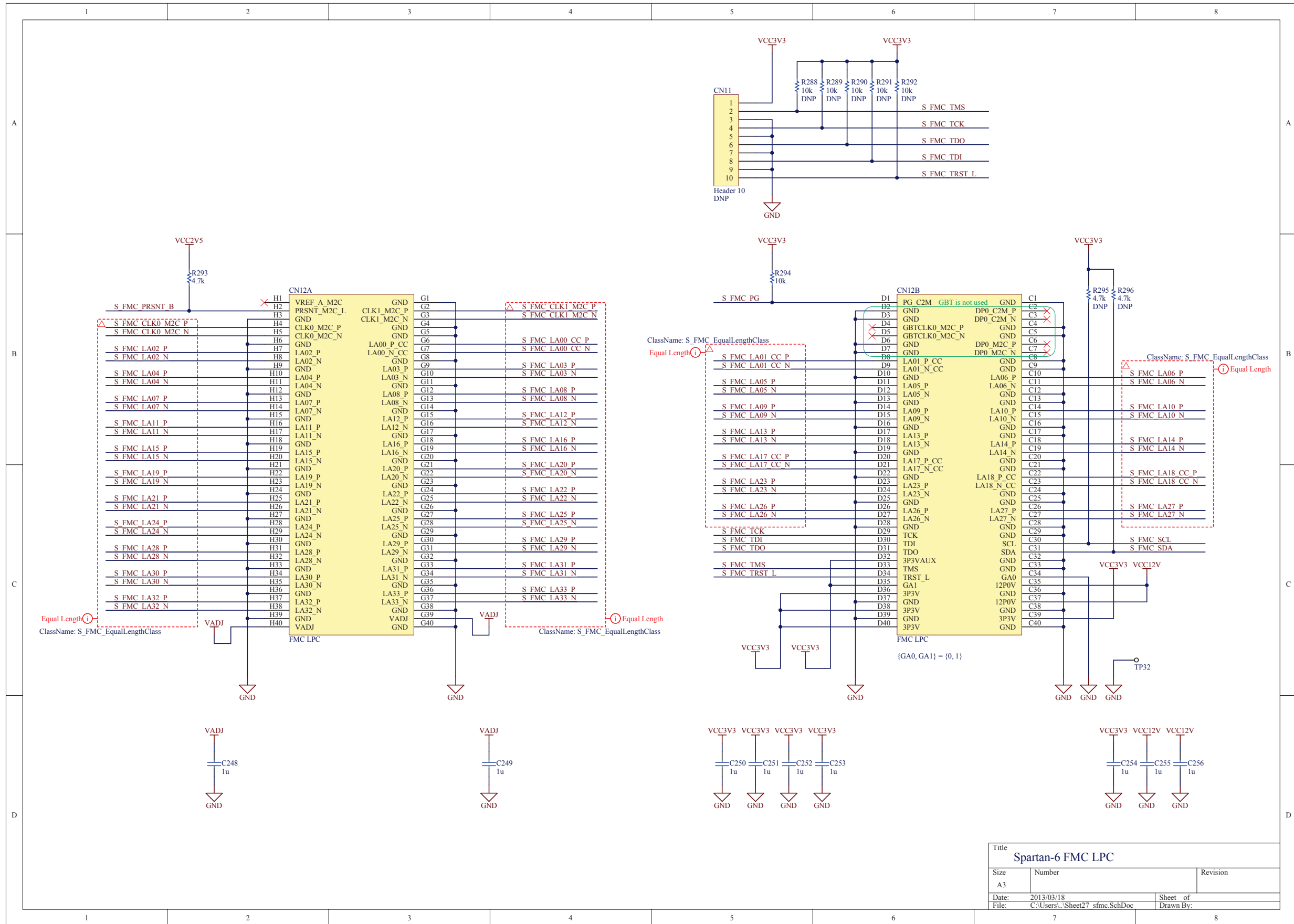

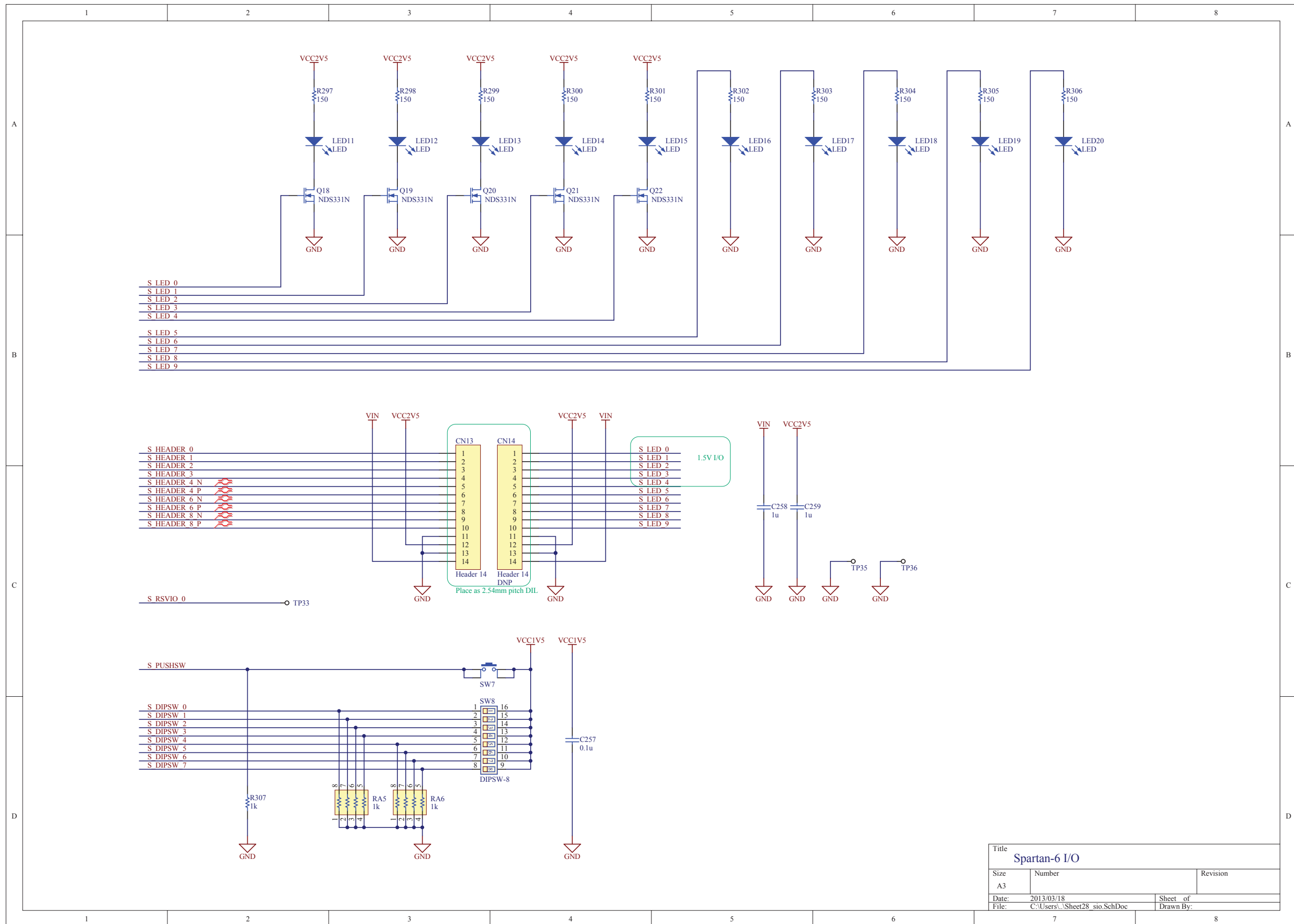

Title Spartan-6 I/O		
Size A3	Number	Revision
Date: 2013/03/18	Sheet of	
File: C:\Users\...Sheet28_sio.SchDoc	Drawn By:	

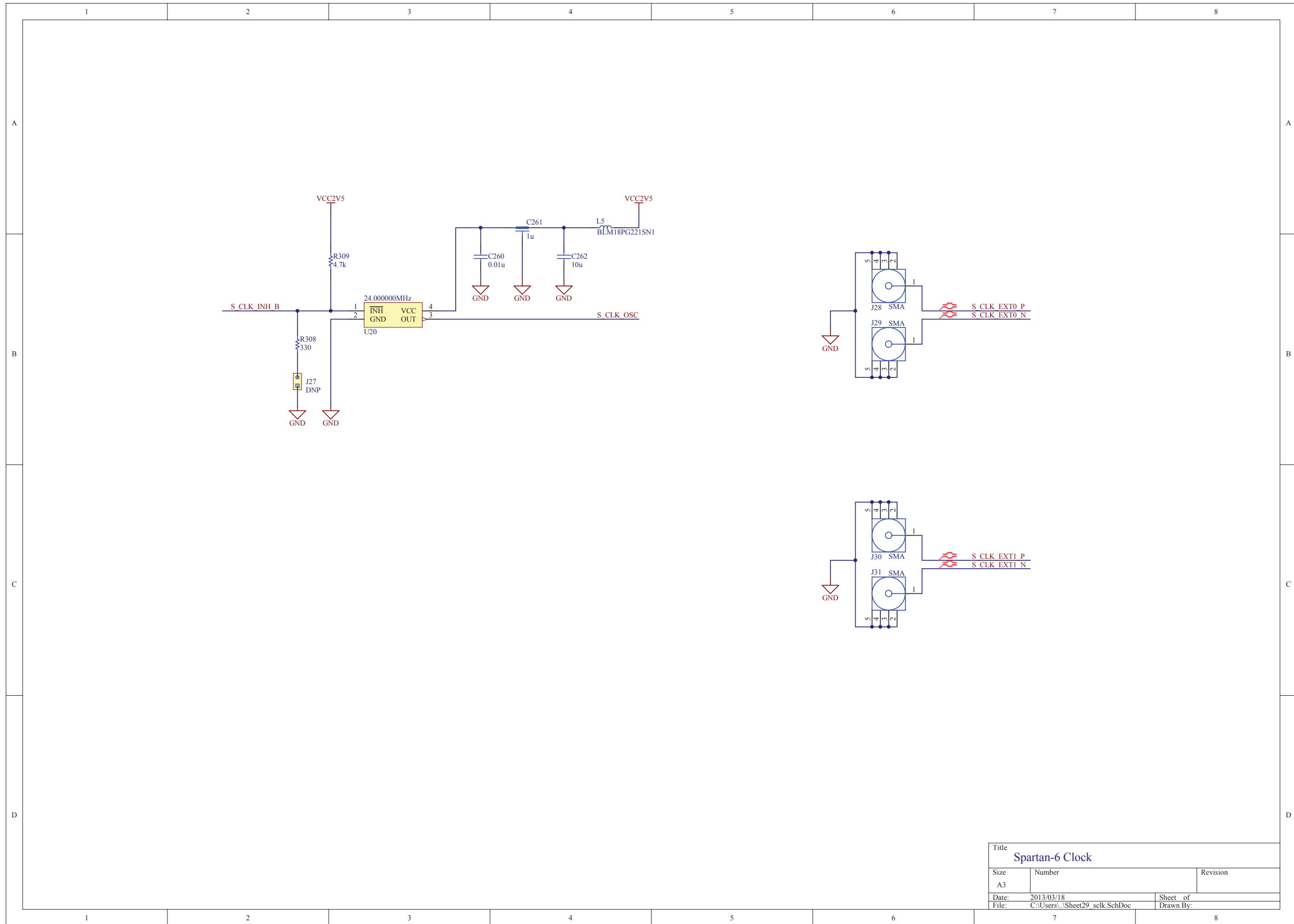

Title		
Spartan-6 Clock		
Size	Number	Revision
A3		
Date:	2013/03/18	Sheet of
File:	C:\Users\...\Sheet29_sclk.SchDoc	Drawn By:

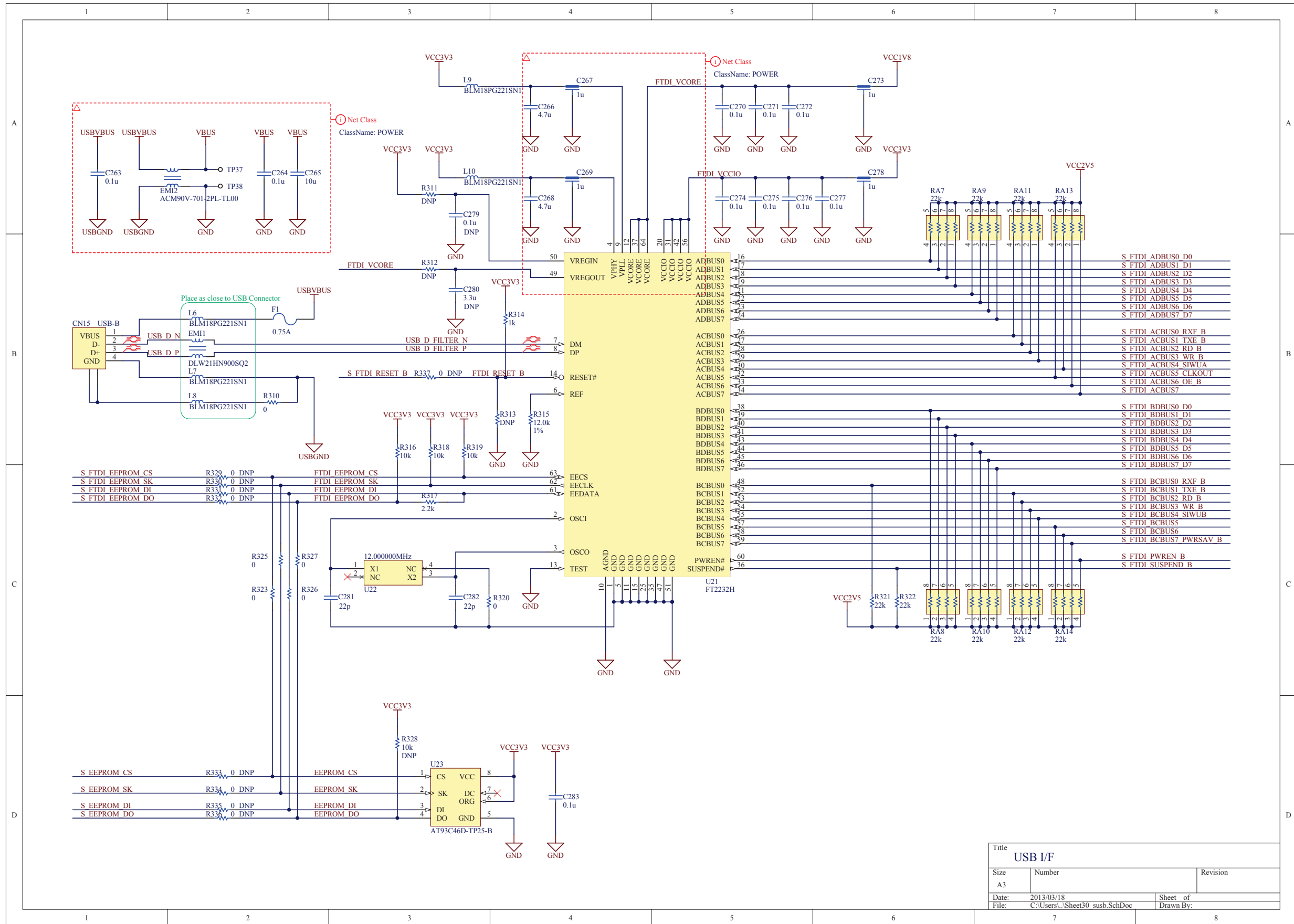

Title		
USB I/F		
Size	Number	Revision
A3		
Date:	2013/03/18	Sheet of
File:	C:\Users\... \Sheet30_susb.SchDoc	Drawn By:

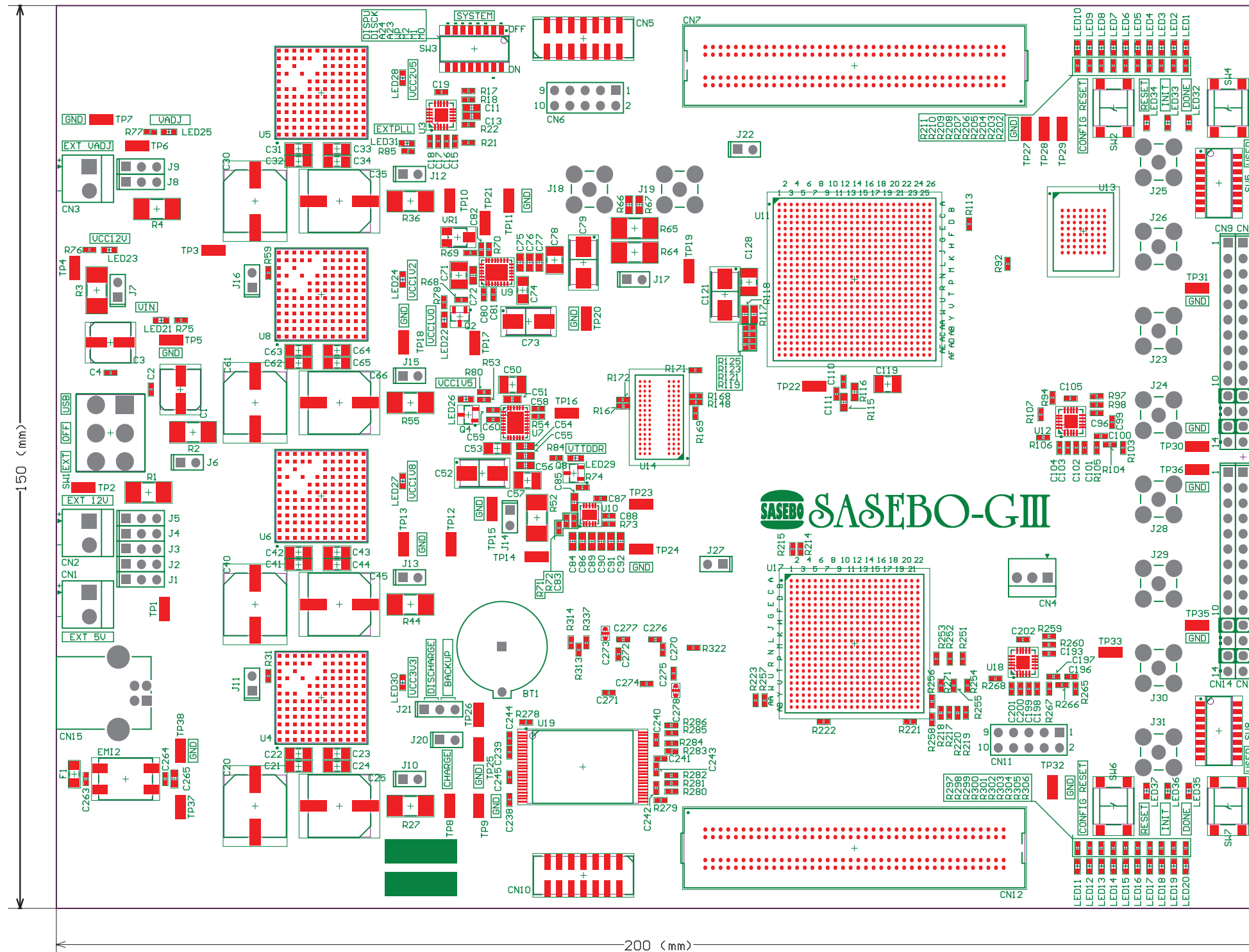

Figure 9 : L1 Assembly Image

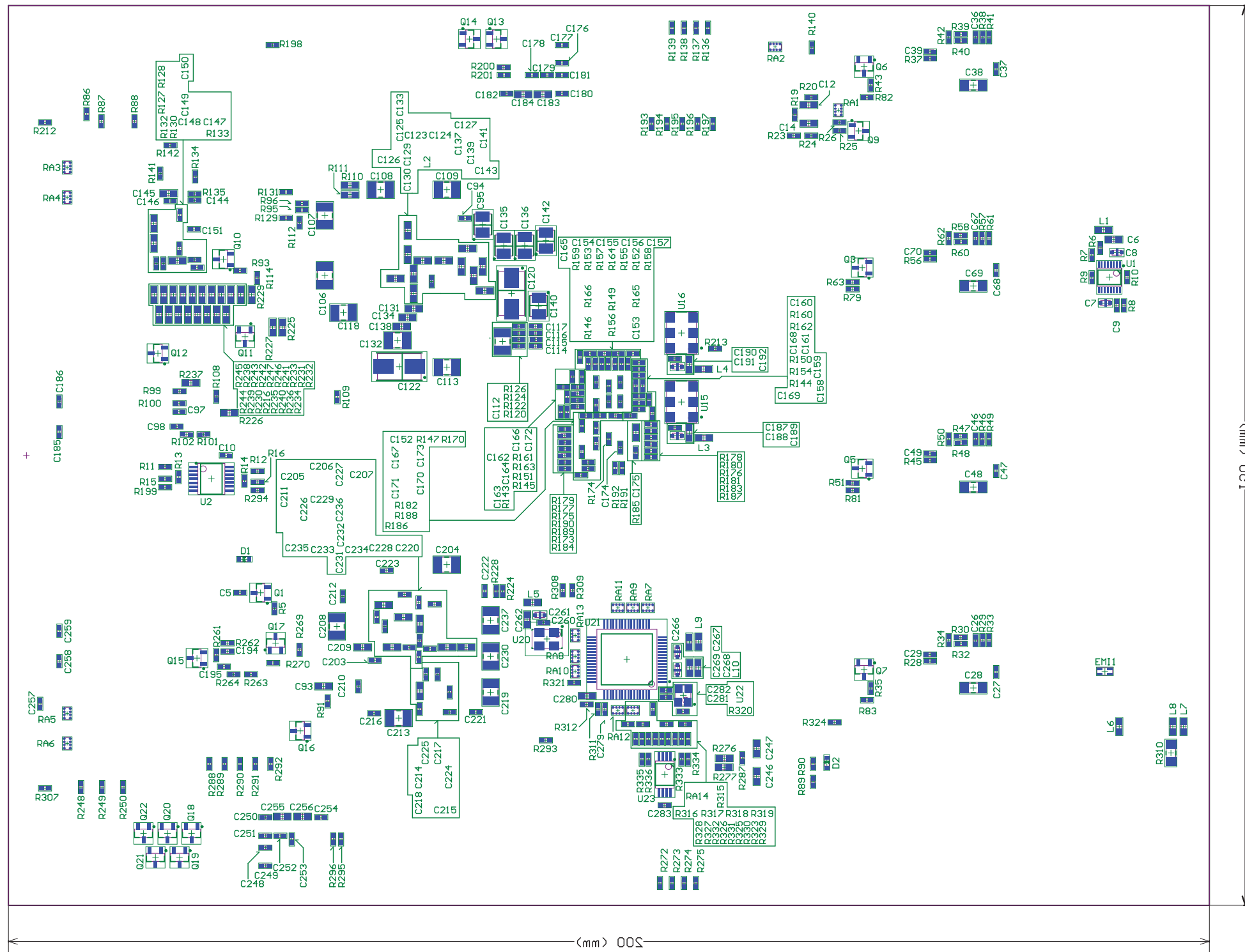

Figure 10 : L8 Assembly Image (Flipped)

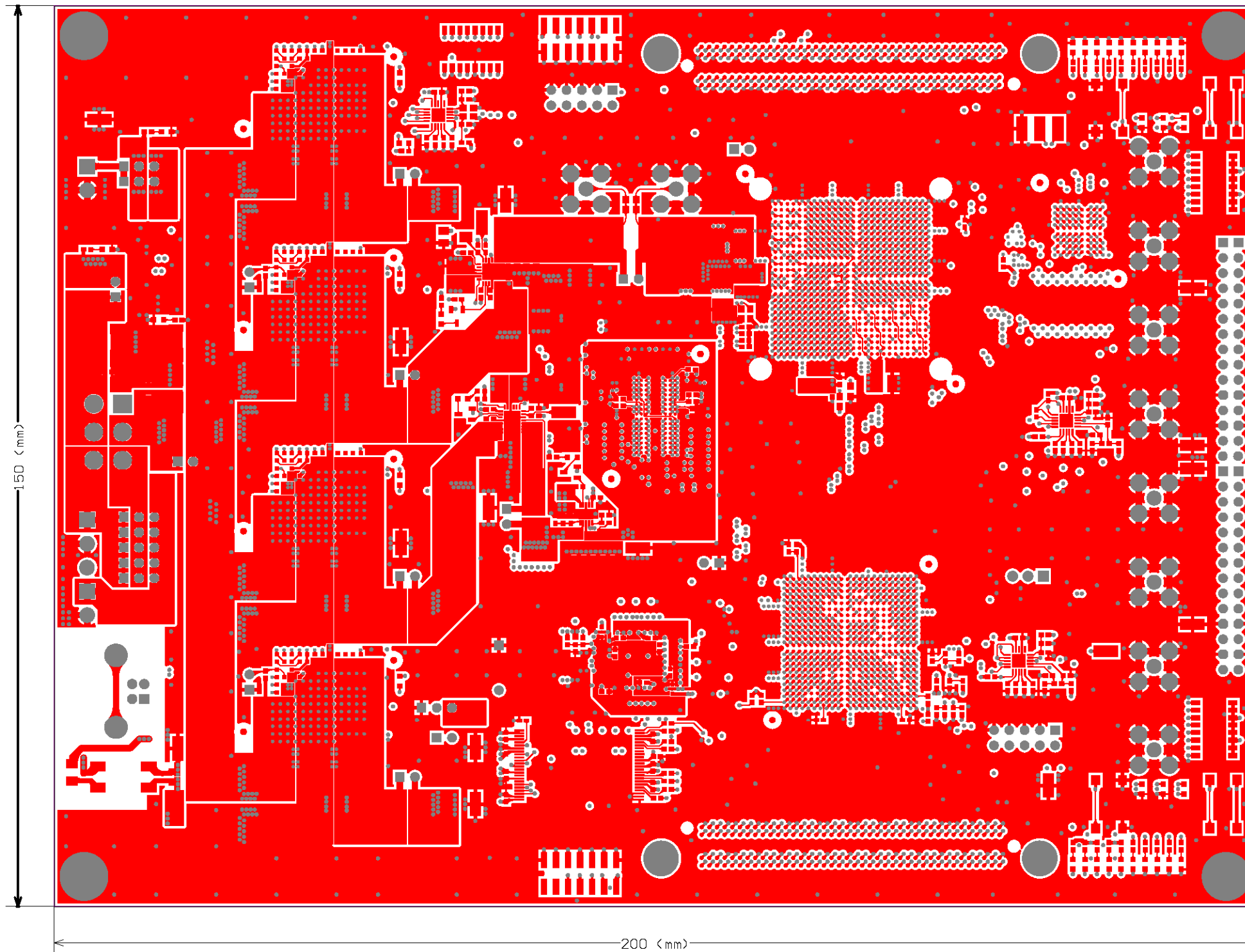

Figure 11 : L1 Pattern

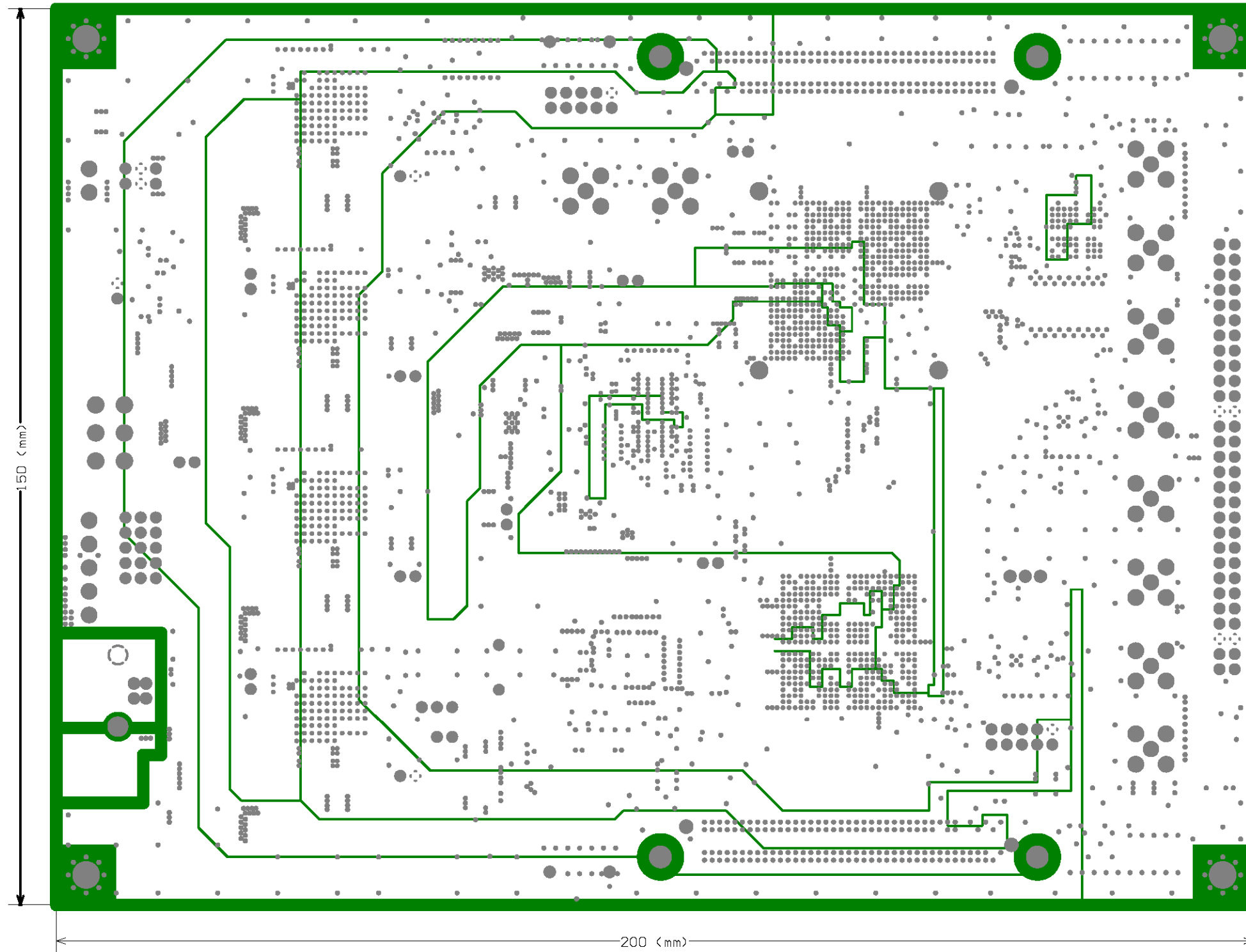

Figure 12 : L2 Cut Pattern

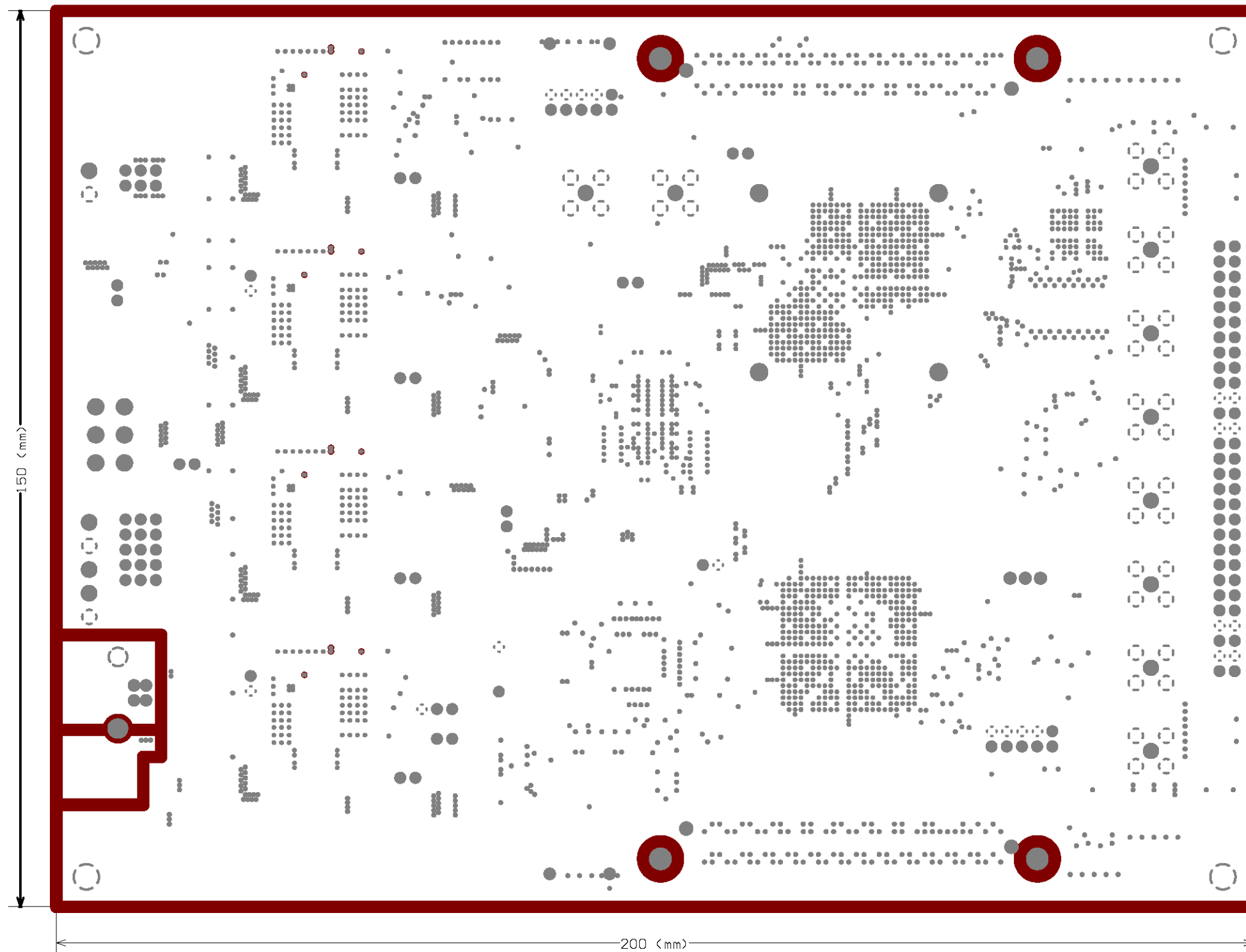

Figure 13 : L3 Cut Pattern

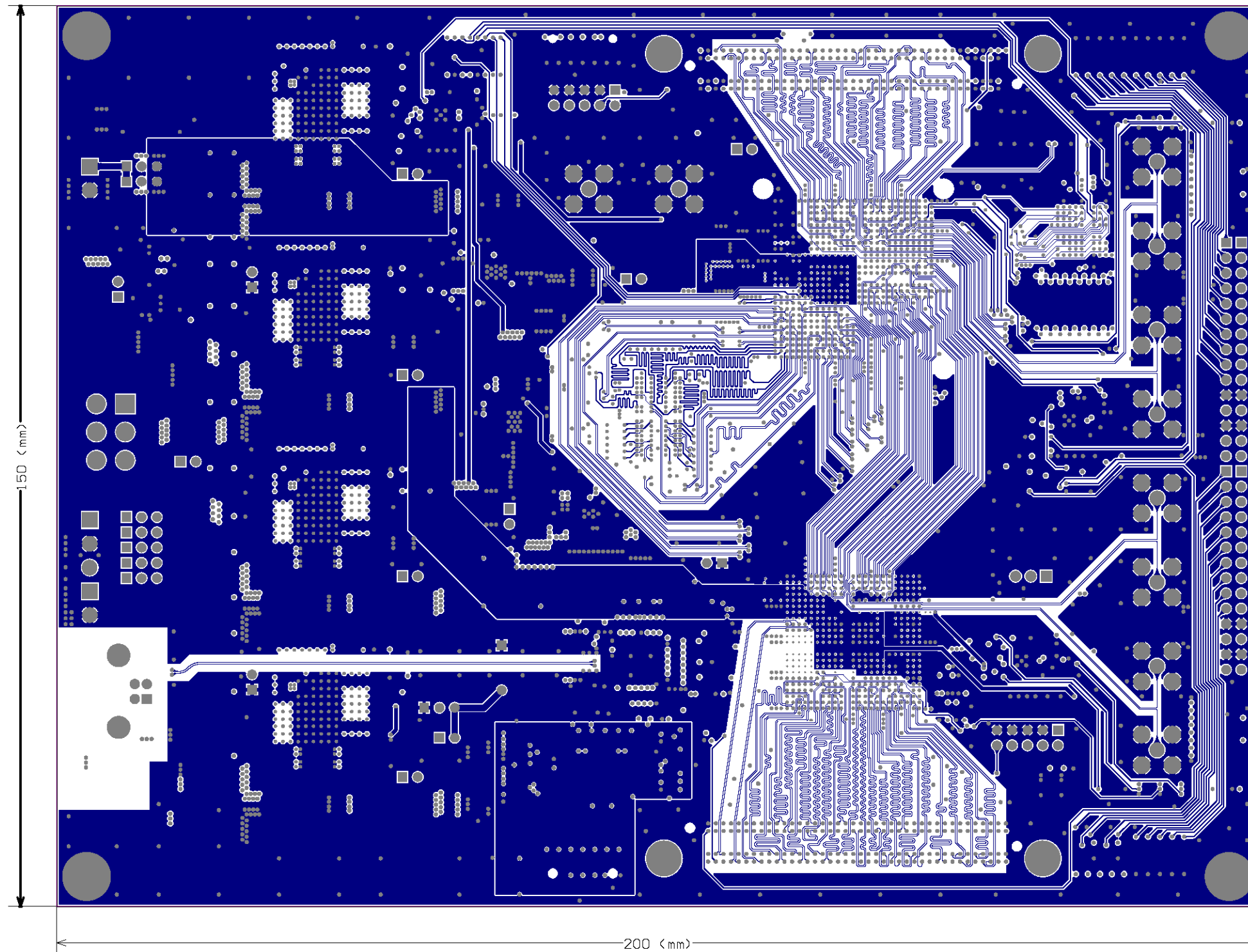

Figure 14 : L4 Pattern

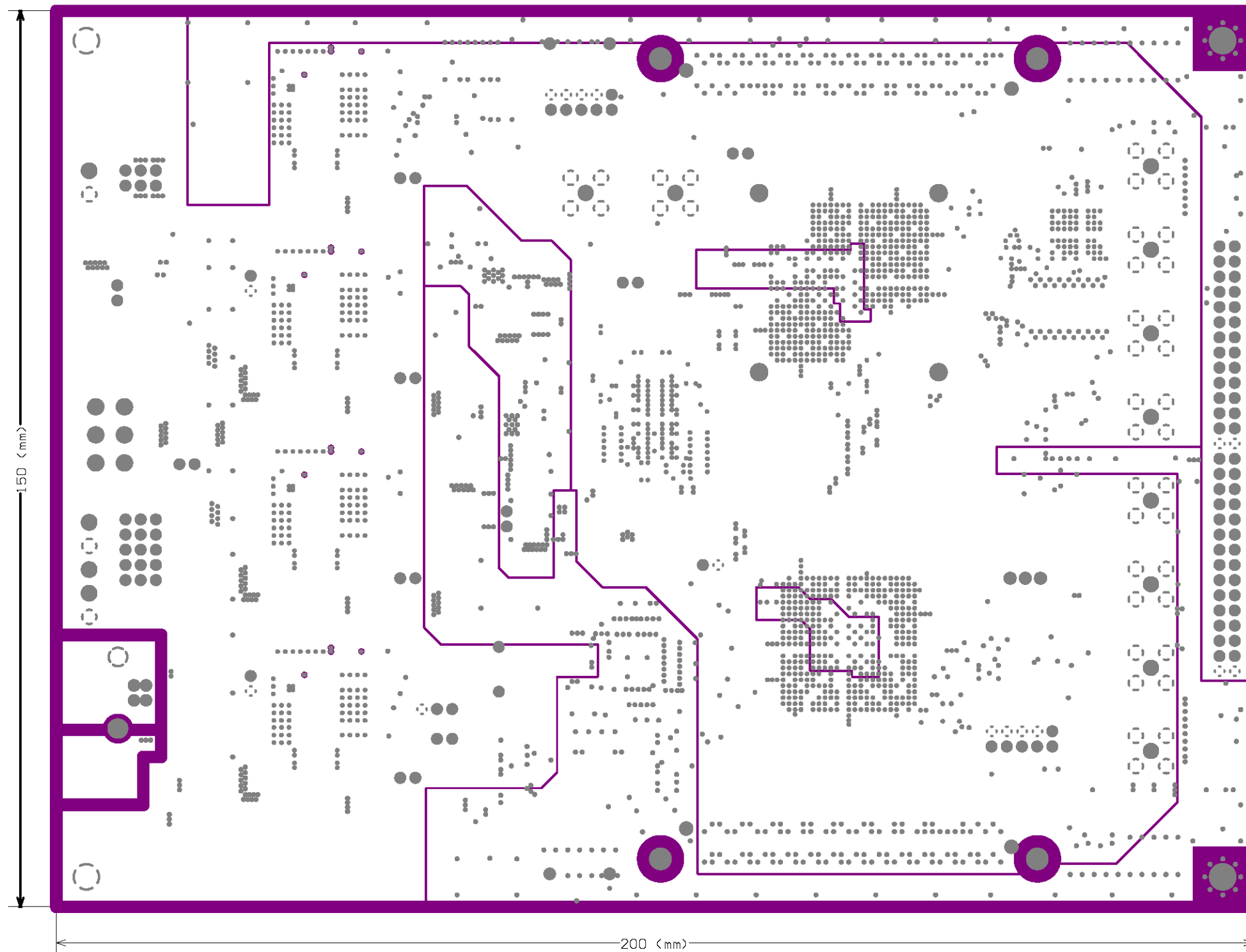

Figure 15 : L5 Cut Pattern

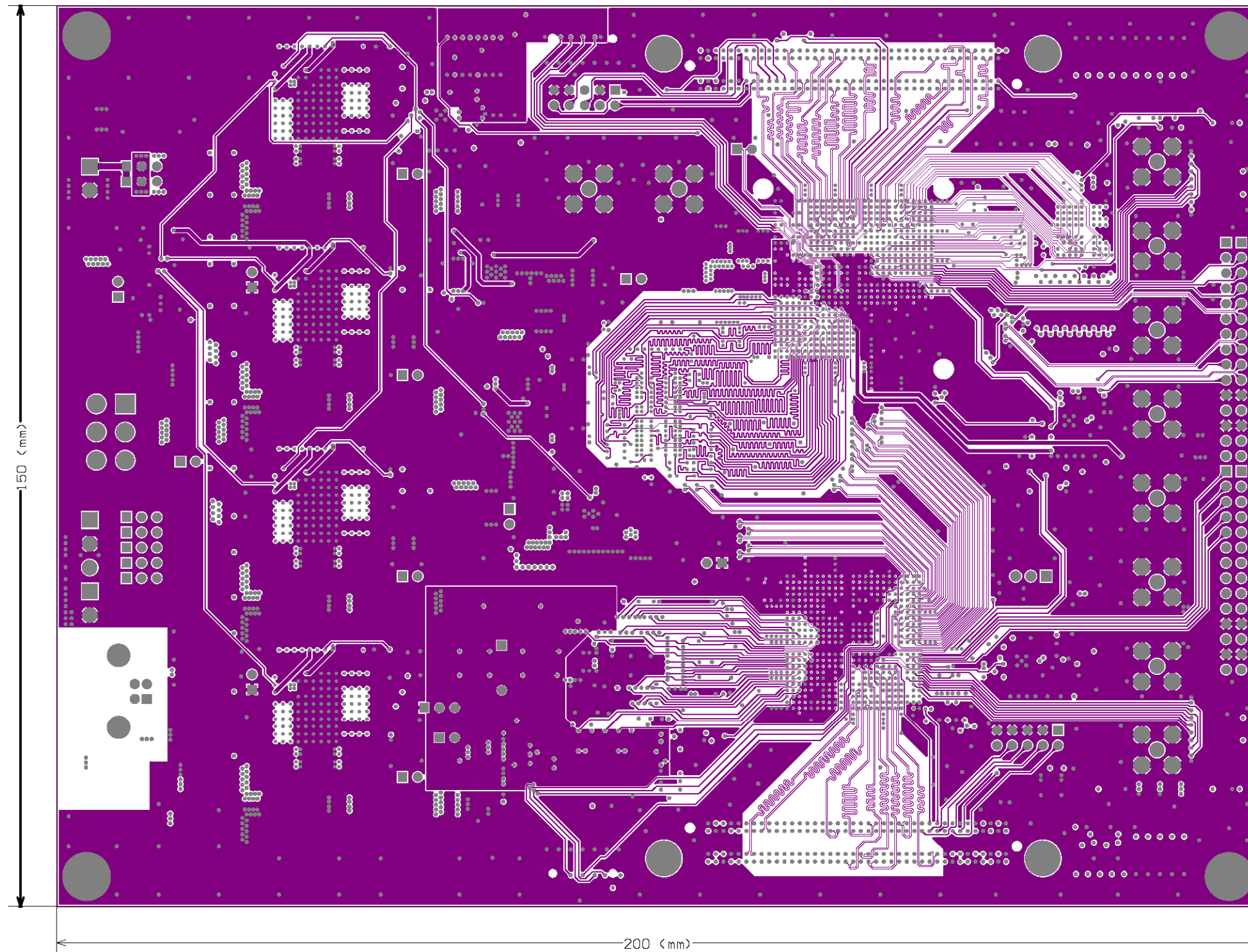

Figure 16 : L6 Pattern

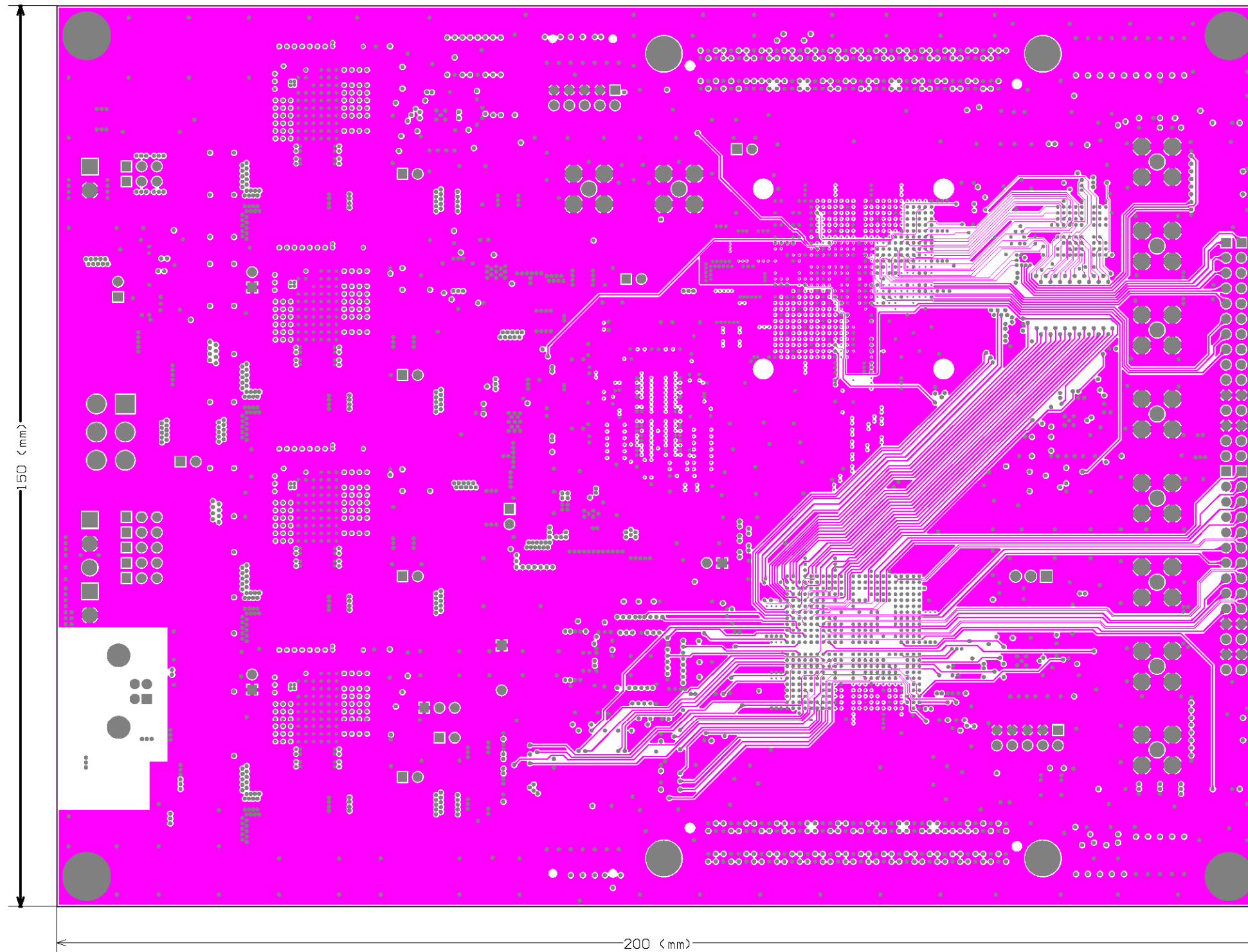

Figure 17 : L7 Pattern

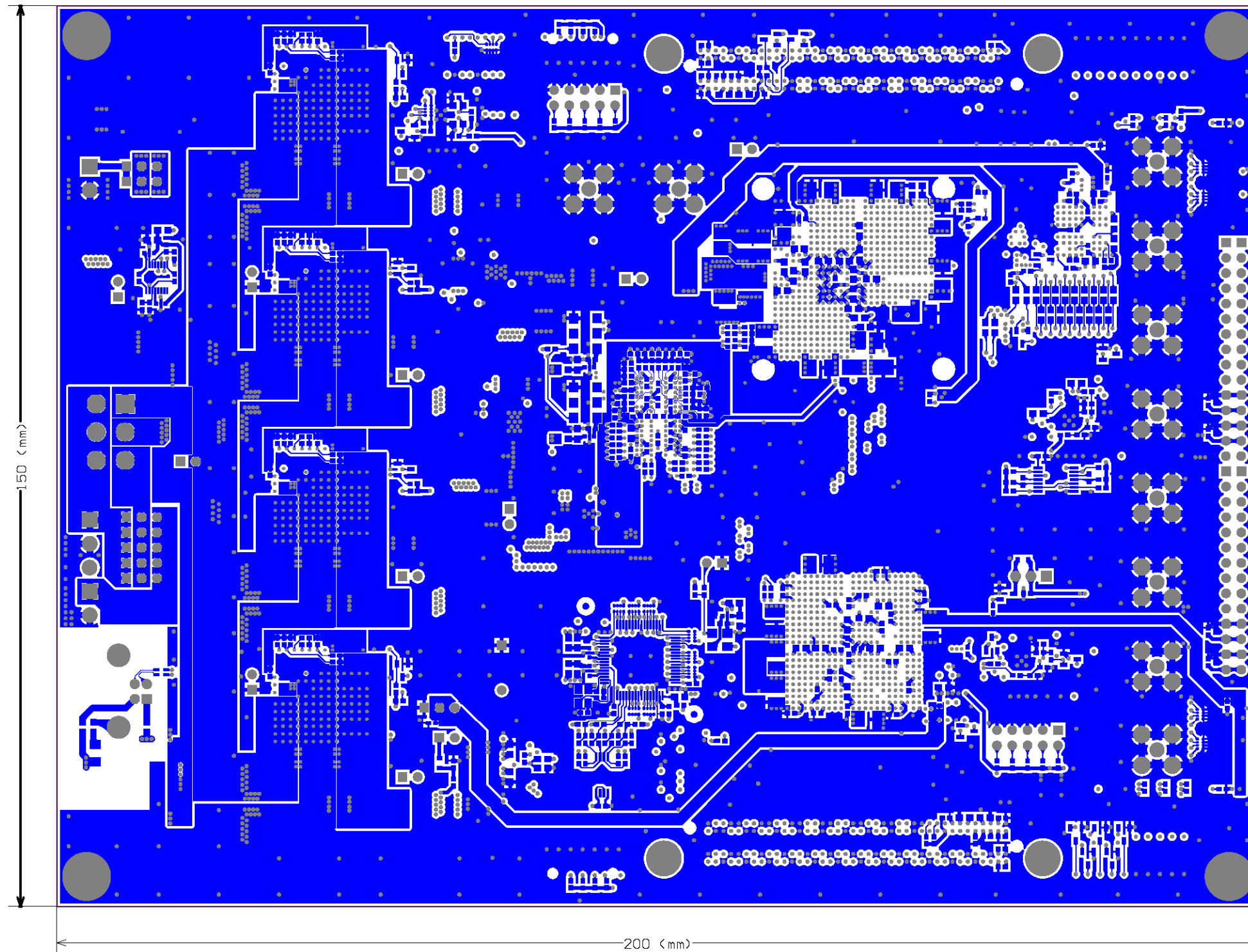

Figure 18 : L8 Pattern

The SASEBO-GIII board was developed by AIST undertaking projects sponsored by JST (Japan Science and Technology Agency)

1. The copyright of this product belongs to the National Institute of Advanced Industrial Science and Technology (AIST).
2. Copying this document and product, in whole or in part, is prohibited without written permission from the copyholders.
3. Only personal or research use of this document and product is granted. Any other use of this document and product is not allowed without written permission from the copyholders.
4. The specifications of this product are subject to revision without notice.

Technical inquiries:

National Institute of Advanced Industrial Science and Technology (AIST)

AIST Tsukuba Central 2 Room 4408

1-1, Umezono 1-Chome Tsukuba-shi, Ibaraki 305-8568, Japan

TEL: +81-29-861-2984

FAX: +81-29-861-5285